

LATL:CS:IP:2021-22

February 9, 2022

<b>BSE Limited</b> Listing & Compliance Department Phiroze Jeejeebhoy Towers, Dalal Street, Mumbai - 400001	<b>The National Stock Exchange of India Limited</b> Listing & Compliance Department Exchange Plaza, C-1 Block G, Bandra Kurla Complex, Bandra (E), Mumbai – 400051
<b>Security Code : 532796</b>	<b>Symbol: LUMAXTECH</b>

**Subject: Investor Presentation for the 3<sup>rd</sup> Quarter and Nine Months ended December 31, 2021**

Dear Sir/ Ma'am,

Please find enclosed herewith the Investor Presentation of the Company for the 3<sup>rd</sup> Quarter and Nine Months ended December 31, 2021.

The same shall also be made available on the website of the Company [www.lumaxworld.in/lumaxautotech](http://www.lumaxworld.in/lumaxautotech).

This is for your information and records.

Thanking you,

Yours faithfully,

For Lumax Auto Technologies Limited



**ANIL TYAGI**  
**COMPANY SECRETARY**  
**M. NO. A 16825**



Encl: As Stated above



# Lumax Auto Technologies Limited

Investor Presentation – Q3 FY21-22



This presentation and the accompanying slides (the “Presentation”), which have been prepared by **Lumax Auto Technologies Limited** (the “Company”), have been prepared solely for information purposes and do not constitute any offer, recommendation or invitation to purchase or subscribe for any securities, and shall not form the basis or be relied on in connection with any contract or binding commitment whatsoever. No offering of securities of the Company will be made except by means of a statutory offering document containing detailed information about the Company.

This Presentation has been prepared by the Company based on information and data which the Company considers reliable, but the Company makes no representation or warranty, express or implied, whatsoever, and no reliance shall be placed on the truth, accuracy, completeness, fairness and reasonableness of the contents of this Presentation. This Presentation may not be all inclusive and may not contain all of the information that you may consider material. Any liability in respect of the contents of, or any omission from, this Presentation is expressly excluded.

Certain matters discussed in this Presentation may contain statements regarding the Company’s market opportunity and business prospects that are individually and collectively forward-looking statements. Such forward-looking statements are not guarantees of future performance and are subject to known and unknown risks, uncertainties and assumptions that are difficult to predict. These risks and uncertainties include, but are not limited to, the performance of the Indian economy and of the economies of various international markets, the performance of the industry in India and world-wide, competition, the company’s ability to successfully implement its strategy, the Company’s future levels of growth and expansion, technological implementation, changes and advancements, changes in revenue, income or cash flows, the Company’s market preferences and its exposure to market risks, as well as other risks. The Company’s actual results, levels of activity, performance or achievements could differ materially and adversely from results expressed in or implied by this Presentation. The Company assumes no obligation to update any forward-looking information contained in this Presentation. Any forward-looking statements and projections made by third parties included in this Presentation are not adopted by the Company and the Company is not responsible for such third party statements and projections.



# Lumax-DK Jain Group



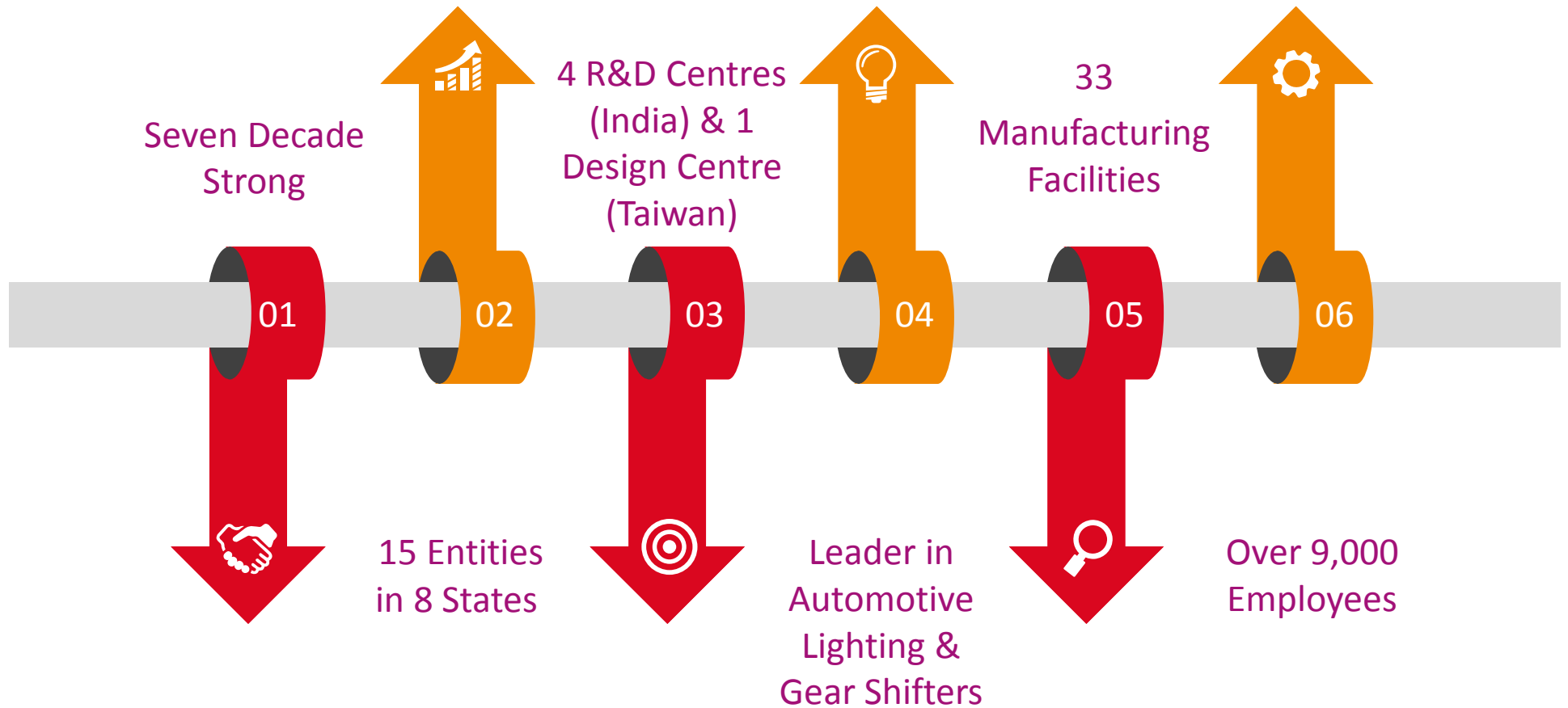

# Two Listed Entities



## Lumax Industries Limited

### Products & Services

End-to-end Automotive Lighting Solutions

HVAC Panels and other electronic components

### Partnerships

- Stanley – Japan
- SL Corporation - Korea

## Lumax Auto Technologies Limited

### Products & Services

Integrated Plastic modules, 2-wheeler Chassis, 2/3-wheeler Lighting, Gear Shifters, Emission systems, Transmission Products, Seat Frames, Aftermarket, Telematics Products and Services, Oxygen Sensors, On-board Antennas, Electric devices and components including software related to automotive industry

### Partnerships

- Cornaglia – Italy
- Mannoh – Japan
- Ituran – Israel
- FAE – Spain
- JOPP – Germany
- YOKOWO – Japan
- Alps Alpine – Japan

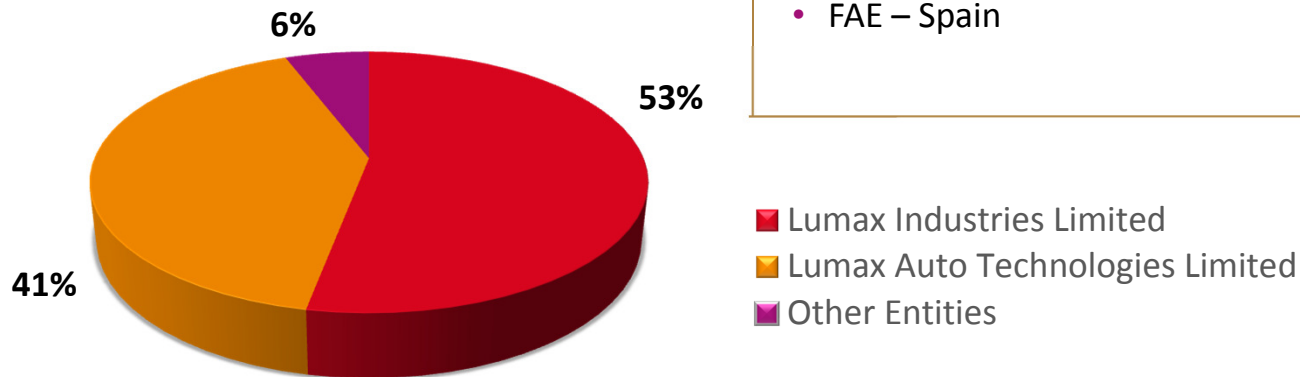

FY21 Group Revenue Break Up (%)



# Purpose, Vision & Values



We deliver **PRIDE** and  
**PROGRESS** with  
**POSITIVITY**



**Our  
Group  
Purpose**

**Respect**  
**Integrity**  
**Passion**  
**Excellence**



**Our  
Values**

Building an **ADMIRED**  
**HIGH PERFORMANCE**  
Global Organisation in  
whom all stakeholders  
have **ABSOLUTE TRUST**



**Our  
Vision**



# Diversified Product Range – 4-wheelers

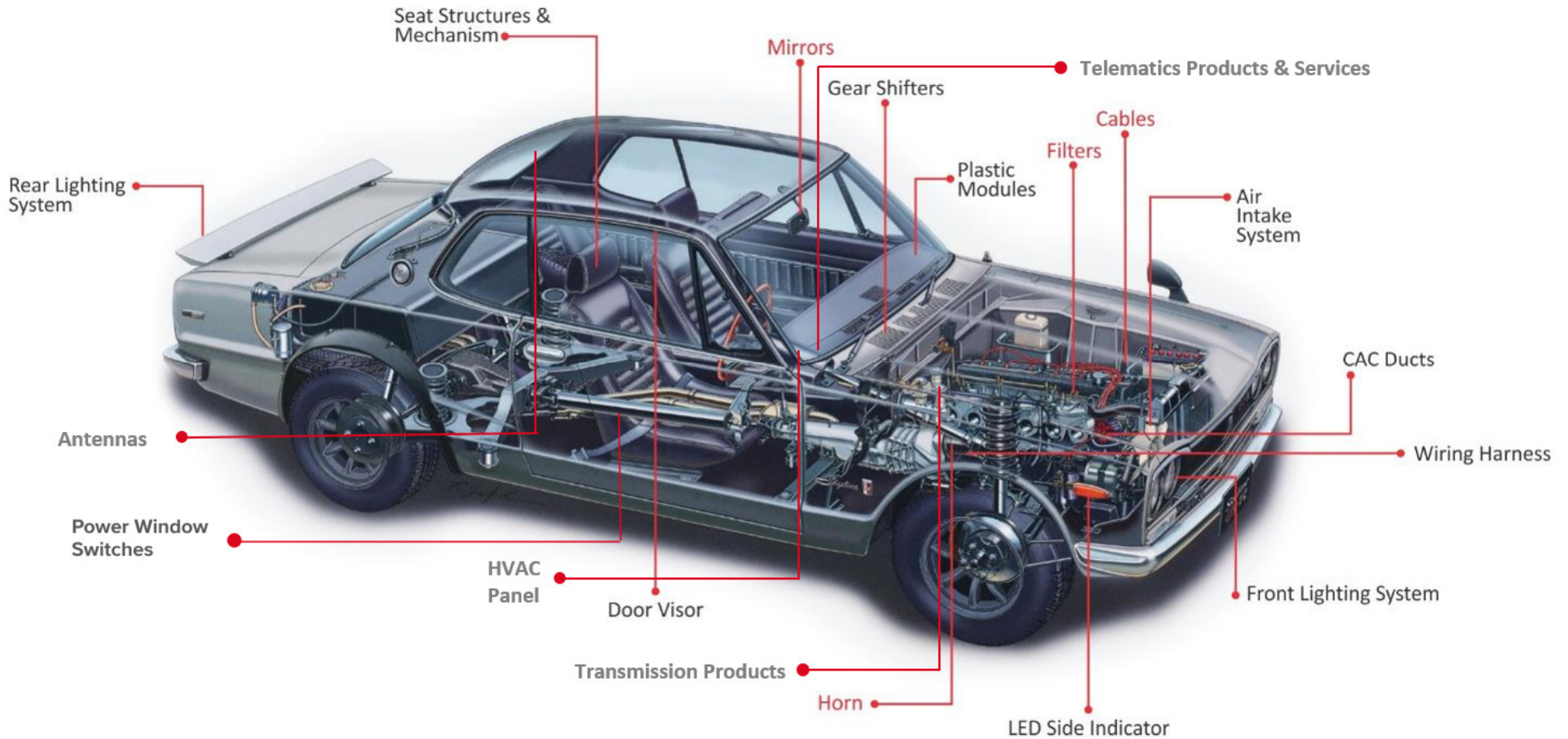

- Destination Boards & Urea Tanks for Commercial Vehicle  
*Aftermarket products*



# Diversified Product Range – 2-wheelers

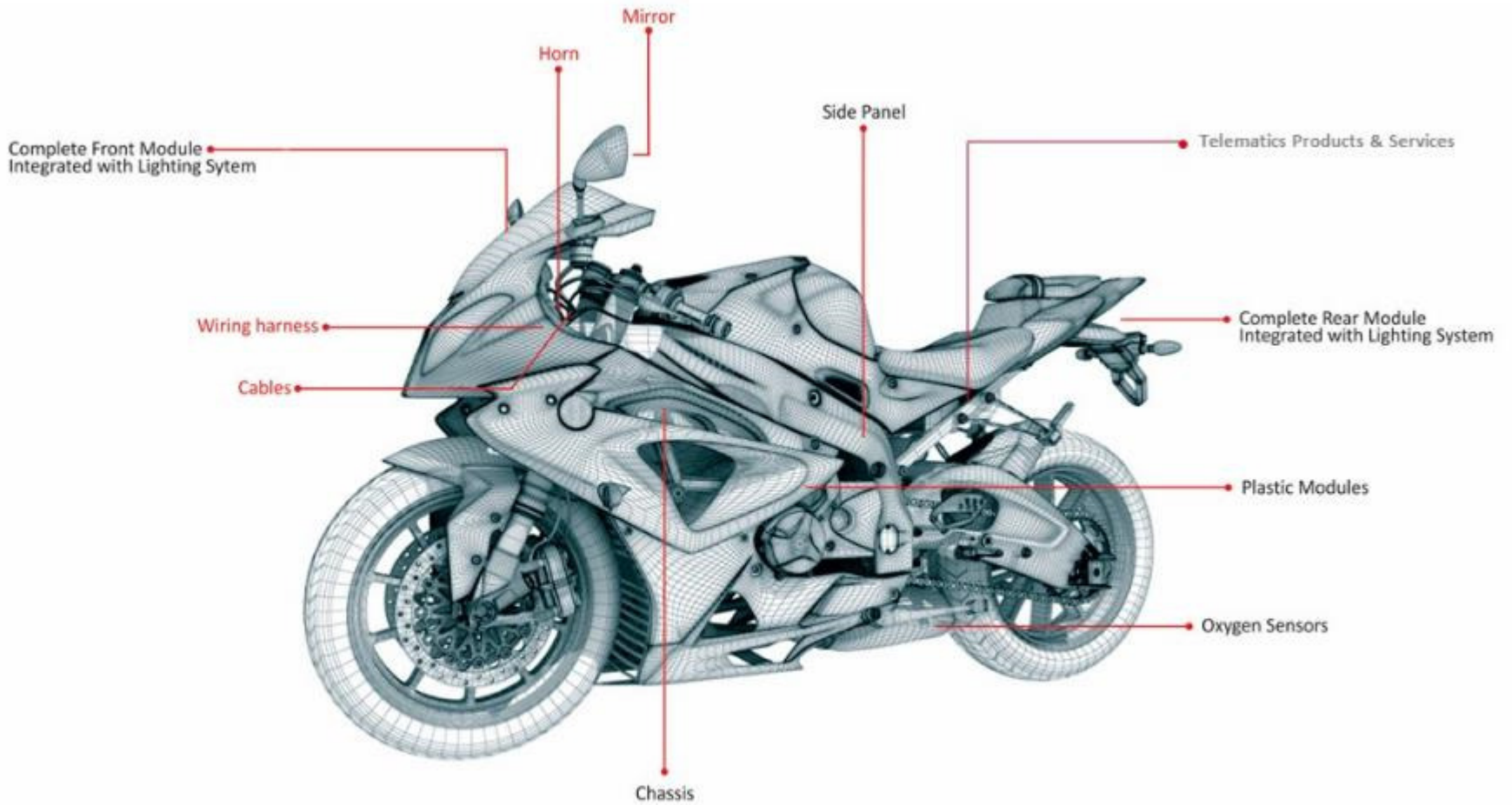

■ *Aftermarket products*

# Diversified Product Range – Commercial Vehicles

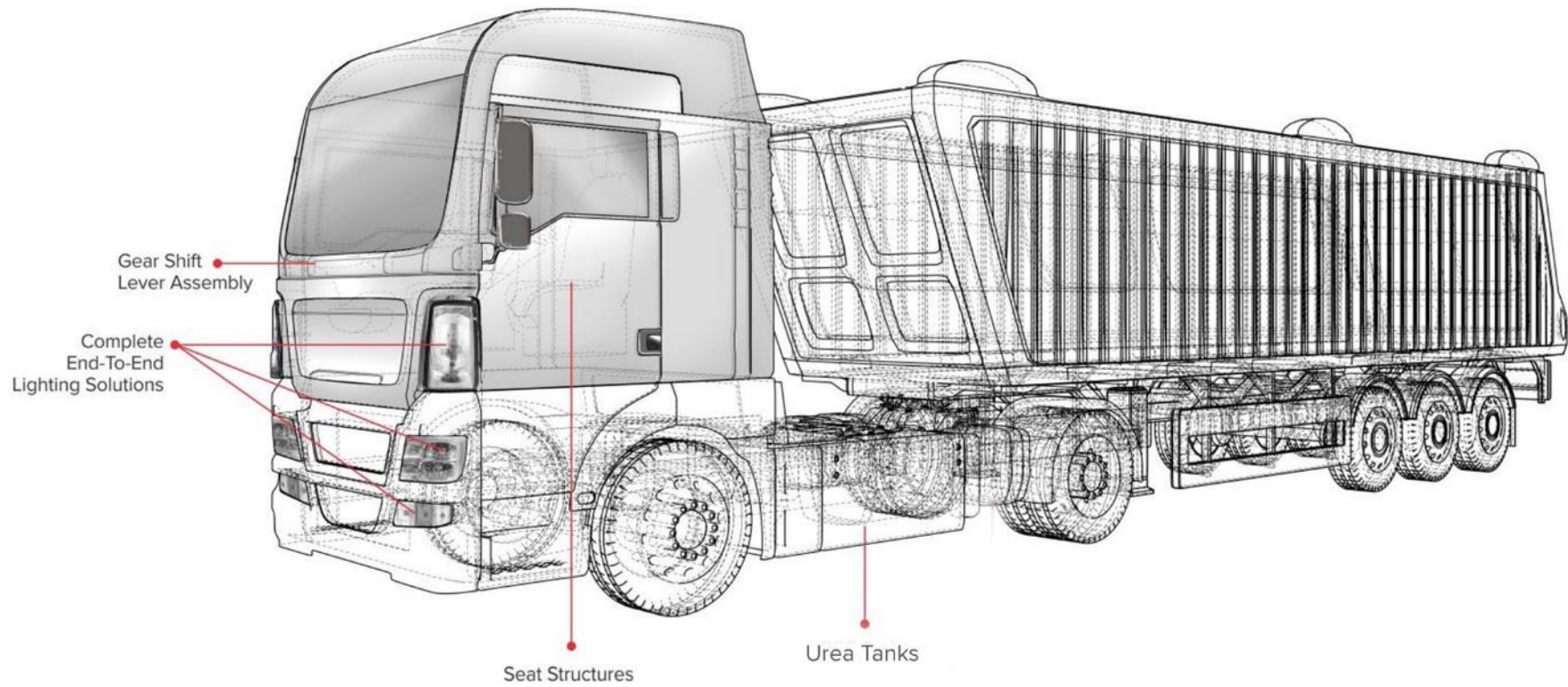

# Diversified Product Range – Farm Equipment Sector (FES)

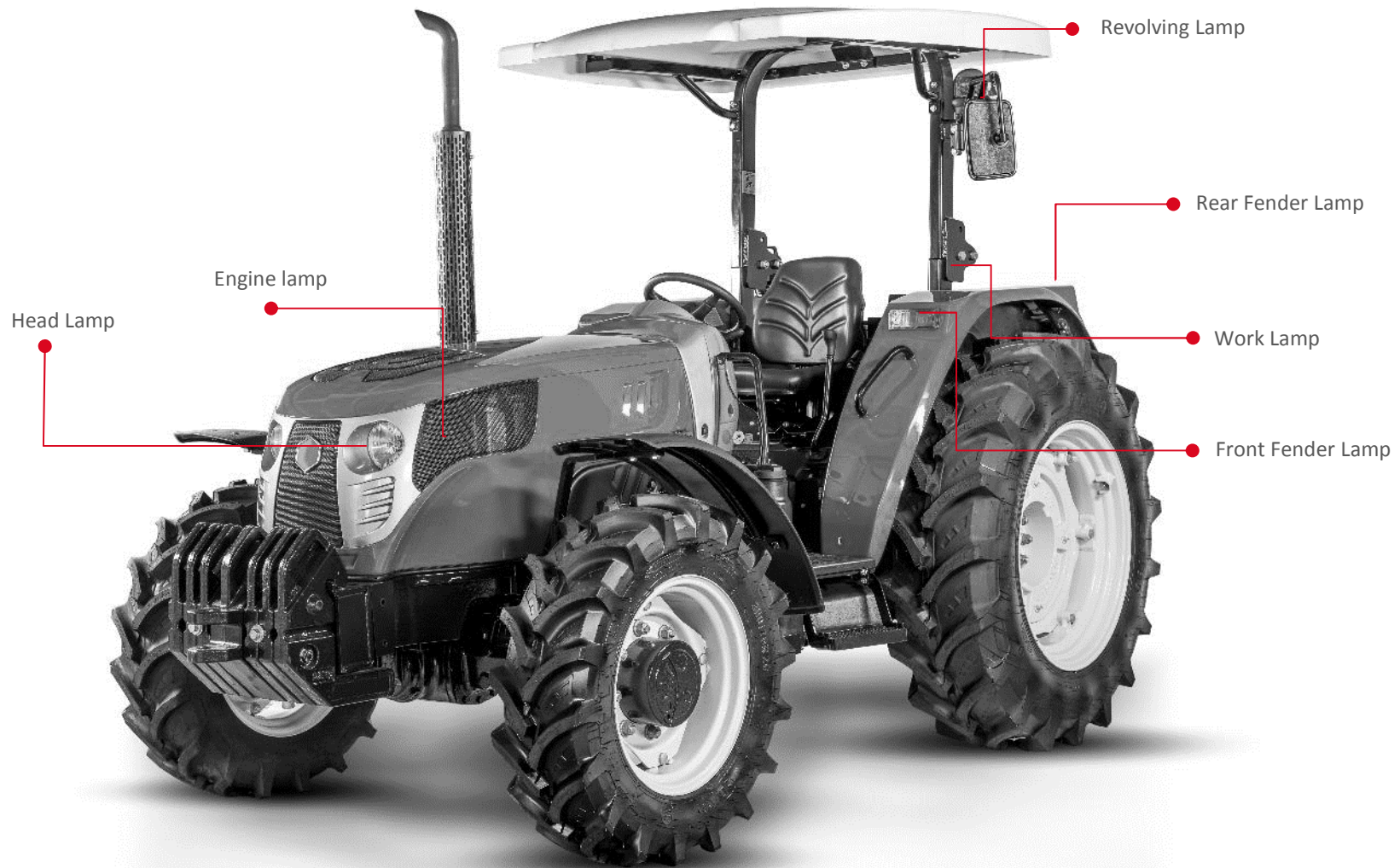

# 33 Locations close to Customers

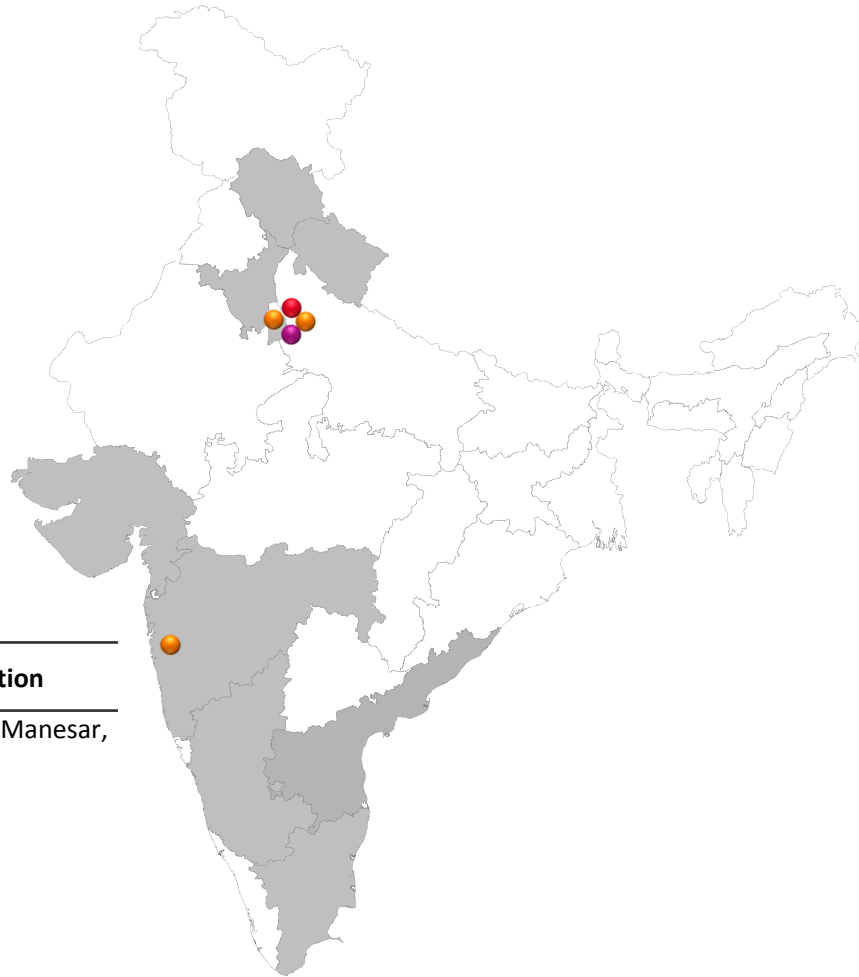

Facilities	Location
● R&D Centre	Gurugram, Manesar, Pune
● Design Centre	Taiwan
● Corporate HQ	Gurugram
● After Market Division	Gurugram

State	Mfg Locations	#
<b>Haryana</b>	Bawal	1
	Dharuhera	1
	Gurugram	4
	Manesar	4
<b>Maharashtra</b>	Pune	9
	Waluj	2
<b>Karnataka</b>	Bengaluru	2
<b>Gujarat</b>	Sanand	1
	Mehsana	1
<b>Tamil Nadu</b>	Sriperumbudur	1
<b>Andhra Pradesh</b>	Anantpur	1
<b>Uttarakhand</b>	Haridwar	1
	Pantnagar	4
<b>Himachal Pradesh</b>	Kale Amb	1
<b>Total</b>		33

## 33 Plants in 8 States

Lumax Industries Limited & Lumax Auto Technologies Limited, along with its subsidiaries, JVs & Associates



# Fostering Partnerships to Deliver Excellence



**Japan**

**Relationship Since 1984**  
JV for lighting, HVAC panels and other electronics  
**37.5% in Lumax Industries Ltd.**



**Korea**

**Relationship Since 1997**  
JV for lighting and other automotive parts  
**78.72% in SL Lumax Ltd.**



**Italy**

**Relationship Since 2007**  
JV for emission systems  
**50% in Lumax Cornaglia Auto Technologies Pvt. Ltd.**



**Japan**

**Relationship Since 2008**  
JV for gear shifters  
**45% in Lumax Mannoh Allied Technologies Ltd.**



**Israel**

**Relationship Since 2017**  
JV for sale of telematics products and services  
**50% in Lumax Ituran Telematics Pvt. Ltd.**



**Spain**

**Relationship Since 2017**  
JV for oxygen sensors  
**16% in Lumax FAE Technologies Pvt. Ltd.**



**Germany**

**Relationship Since 2019**  
JV for manufacture and supply of transmission products  
**50% in Lumax Jopp Allied Technologies Ltd.**



**Japan**

**Relationship Since 2020**  
JV for manufacture and supply of antennas & other vehicle communication products  
**50% in Lumax Yokowo Technologies Pvt. Ltd.**



**Japan**

**September 2021**  
JV for manufacture and supply of electric devices and components  
**50% in Lumax Alps Alpine India Pvt. Ltd.**

# Relationships with Diversified Customers



## Two Wheeler



## Tier 1



## Four Wheeler



## Commercial Vehicle



The Brand Names mentioned are the property of their respective owners and are used here for identification purposes only

## Tractor/FES



## Defence & Aero Space



## Export



... Strong After Market Exports Presence



**Lumax Auto Technologies Limited**  
Driving Growth through Diversified Products





# Competitive Strengths



## Evolving with Our Partners

Partnered with international automotive leaders to reinforce competitiveness



### Manufacturing Capabilities

- Company's plants are certified under ISO 14001 Standards for Environment Management Systems (EMS)
- Plants equipped with Energy Conservation Equipment



### Award

- **Plants** of the Company have received awards for Quality initiatives in various forums
- Several awards from different customers for meeting and exceeding their targets

## Lumax Brand

Credible LUMAX Brand



### R&D Centre

- Govt certified R&D center
- Frontrunner in the R&D, technology, and innovation space

## Customer Outreach

Strong OEM presence  
Over 300 Channel Partners



### Diversified Product Portfolio

Integrated Plastic modules, 2-wheeler Chassis & Lighting, Gear Shifters, Transmission Products, Emission Systems, Seat Frames, Aftermarket, Oxygen sensors, Telematics Products, Antennas & other vehicle communication products, Electric devices & components

# Milestone



**1981:** Lumax Auto Electricals was established to manufacture 2-wheeler Lighting at Bhosari, Maharashtra

**1988:** Name of the company was changed to **Dhanesh Auto Electricals Pvt Limited**

**1997:** A Unit was setup in Waluj, Maharashtra to manufacture Chassis

**2002:** Setup the Plant at Chakan, Maharashtra to manufacture 2-wheeler Lighting

**2006:** Name of the company was changed to Lumax Auto Technologies Limited

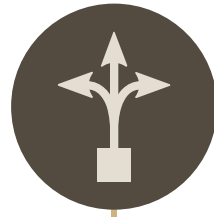

**2013:** Setup a plant at Narsapur, Karnataka to manufacture Moulded parts; Formed **JV with Gill Austem LLC, USA** to manufacture Seat frames & Mechanism

**2014:** **JV company with Mannoh Industrial Company, Japan** started as Lumax Mannoh Allied Technologies Limited

**2015:** Setup another Robotic Motorcycle Chassis plant in Waluj, Maharashtra; Formed JV with Sipal, Italy for Aerospace & Defence Engineering services



**2020:** **JV with Yokowo, Japan** to manufacture and supply Antennas and other vehicle communication products. Start of Commercial Production in Pantnagar, Uttarakhand under LCAT.

Start of Commercial Production by Lumax FAE

Lumax Gill Austem Technologies Pvt Ltd. name changed to Lumax Mettalics Pvt. Ltd. and becomes 100% subsidiary of LATL

**2021:** Start of commercial production of **JV with Alps Alpine** to manufacture and sell electric devices and components including software related to the automotive industry

**2007:** Setup Seat frame manufacturing plant in PCNTDA, Bhosari, Maharashtra.

JV company with Cornaglia, Italy started as **Lumax Cornaglia Auto Technologies Pvt Limited.**

**Listed on Stock Exchange**

**2009:** Entered a **TA with Mannoh Industrial Company, Japan** for manufacturing of Gear Shift Lever

**2011:** Setup state-of-the art Surface Mounted Technology unit in Manesar, Haryana

**2012:** Setup the first Robotic Motorcycle Chassis plant in Waluj, Maharashtra



**2017:** Formed a **JV with Ituran Location and Control Limited, Israel** to provide Telematics Products and Services.

Formed a **JV with FAE, Spain** to manufacture Oxygen Sensors.

Set up Assembly facility in Mehsana, Gujarat under LMAT

**2018:** Setup an R&D center under Lumax Cornaglia Auto Technologies Pvt Limited at Pune

**2019:** Inauguration of Chassis facility at Aurangabad

**JV with JOPP, Germany** to manufacture and supply transmission products

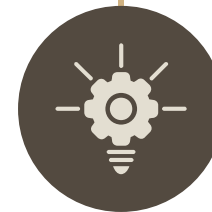

# Well defined Corporate Structure

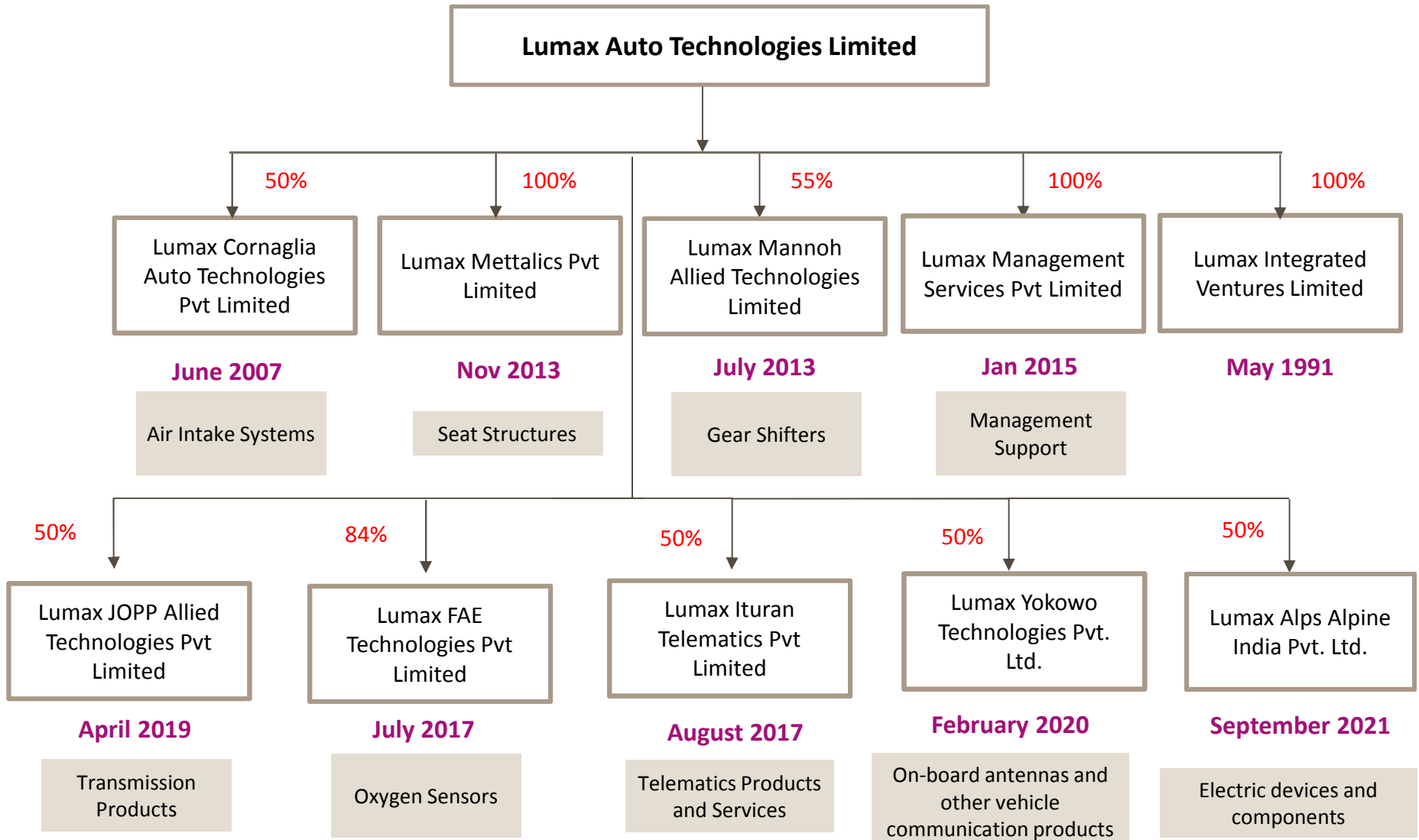

Date of Incorporation



# Fostering Partnerships to Deliver Excellence



**Italy**

**Relationship Since 2007**  
JV for emission systems  
**50% in Lumax Cornaglia Auto Technologies Pvt. Ltd.**



**Japan**

**Relationship Since 2008**  
JV for gear shifters  
**45% in Lumax Mannoh Allied Technologies Ltd.**



**Israel**

**Relationship Since 2017**  
JV for sale of telematics products and services  
**50% in Lumax Ituran Telematics Pvt. Ltd.**



**Spain**

**Relationship Since 2017**  
JV for oxygen sensors  
**16% in Lumax FAE Technologies Pvt. Ltd.**



**Germany**

**Relationship Since 2019**  
JV for manufacture and supply of transmission products  
**50% in Lumax Jopp Allied Technologies Ltd.**



**Japan**

**Relationship Since 2020**  
JV for manufacture and supply of antennas & other vehicle communication products  
**50% in Lumax Yokowo Technologies Pvt Ltd.**



**Japan**

**September 2021**  
JV for manufacture and supply of electric devices and components  
**50% in Lumax Alps Alpine India Pvt. Ltd.**



# Cater to Diversified Segments



## After Market Presence in all Segments



- Lighting Module(incl. HL/TL/Indicators & Others)
- Chassis for 2-wheelers
- Fabricated parts for 3-wheelers
- Integrated Plastic Modules
- Oxygen Sensors
- Telematics Products and Services



- Gear Shift Lever
- Gear Shift Tower
- Control Housing
- Intake Systems
- Seat Structures
- Integrated Plastic Modules
- Telematics Products and Services
- Antenna
- Electronic devices & components



- Integrated Plastic Modules
- Gear Shift Lever
- Seat Structures
- Telematics Products and Services
- Urea Tank

# Key Customer Relationships



## Four Wheeler



ŠKODA



SPORT  
UTILITY  
VEHICLES



TOYOTA



## Tier 1



## Commercial Vehicle



## 2/3 Wheeler



BAJAJ  
Distinctly Ahead



## Export



The Brand Names mentioned are the property of their respective owners and are used here for identification purposes only

# Strategic Locations Close to Customers

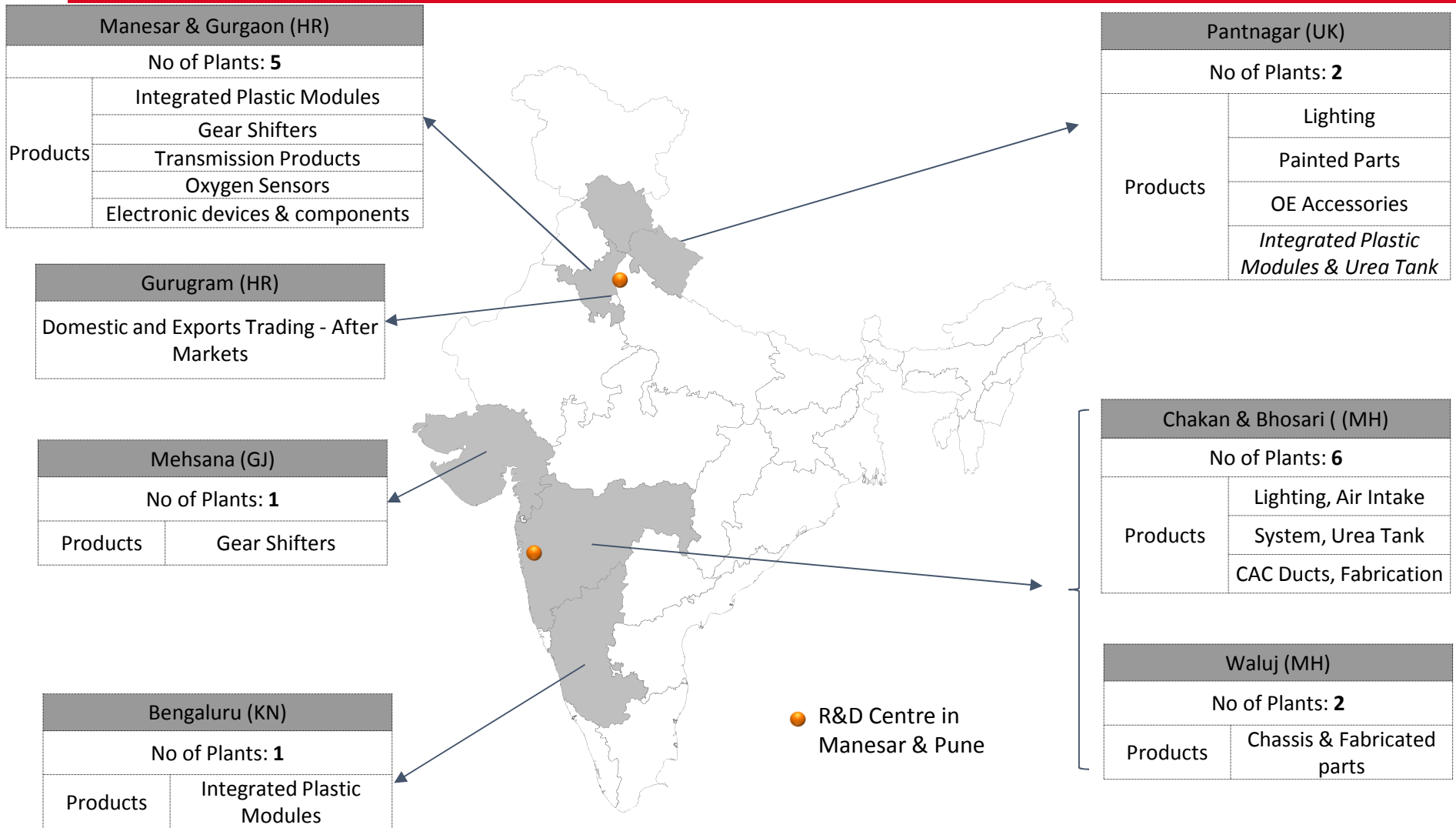

**17 Plants in 5 States**



### Shareholding breakup

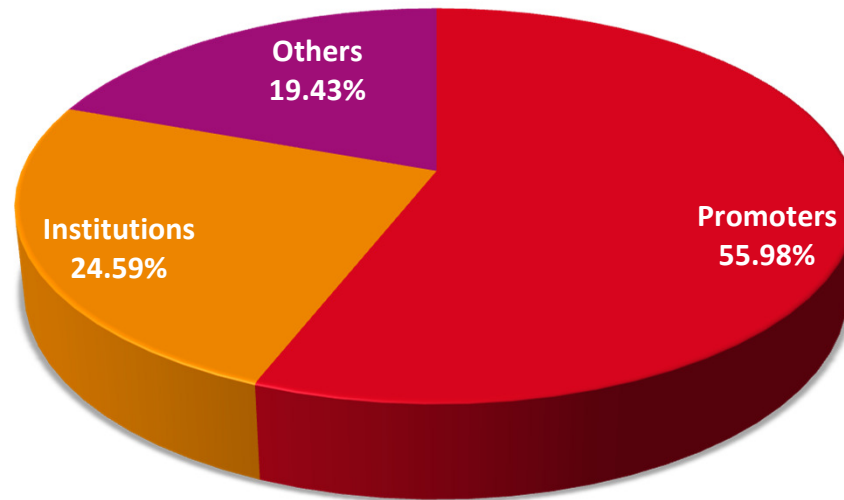



## Experienced Promoters



**Mr. Dhanesh Kumar Jain**  
**Chairman**

- He is 79 years of age & holds a MBA degree from Delhi university & has successfully completed President Management Program from Harvard Business School
- Over 50 years of experience in the automotive industry in management, operations & administrative roles
- He has held various industry positions
  - Past president of ACMA, president suppliers association – Toyota Kirloskar Motors, Chairman of Trade Fairs Committee ACMA, Co-chairman of Regional Committee on Membership of Northern Region CII, Past Chairman of CSR sub-committee of the Northern Region of CII



**Mr. Anmol Jain**  
**Managing Director**

- He is 42 years of age & holds Bachelors in Business Administration in Finance & Supply Chain Management (Double major) from Michigan State University, U.S.A.
- He worked as a Management Trainee with GHSP, U.S.A. & subsequently, joined Lumax Group, in 2000 & has over 20 years of experience
- He has held various positions in Industry associations - He was the National Coordinator of ACMA- YBLF from 2014-16. He was also the Chairman CII Haryana State Council in 2012-13
- He is currently the President of Honda Cars India Supplier's Club & MC member of Bajaj Auto Vendor Association and Executive Council member of ACMA



**Mr. Deepak Jain**  
**Director**

- He is 46 years of age & is a Business Graduate from Illinois Institute of Technology, USA with specialization in Operations Management & International Business
- He has undergone extensive training at Stanley Co. Limited, U.S.A. & Stanley Electric Co. Limited, Japan. He has over 25 years experience
- He is the immediate Past President of ACMA, he was chairman of ACMA's HR/IR & Skill Development Committee, past chairman of Sustainable Technology Development Committee of ACMA, past National Coordinator of Young Business Leader Forum of ACMA and past president of Supplier's club, Honda Cars India Limited.
- He is also Chairman - CII Northern Region - Regional Committee on Advanced Manufacturing and is member of Young President's organization and Entrepreneurs organization. He also holds the position of Vice President of Toyota Kirloskar Supplier's Association

## Supported by Strong Independent Directors



**Mr. Roop Salotra**  
Age: 71 years  
Mechanical Engineer

He retired from SRF Group, after spending 24 years, as CEO & President, is now an advisor to the Managing Director of SRF Limited. He has been actively involved in CII – Climate Change & Environment councils. He is former Chairman of Indian Chemical Council-Northern Region



**Mr. Milap Jain**  
Age: 70 years  
B.A. (Pol.Sc. Hons.)  
from Revenshaw  
College, Cuttack

He is a retired Indian Revenue Service Officer with 38 years of service. He retired as Chief Commissioner of Delhi, Income Tax Department, Govt. of India. Currently he is a Director of Mahavir International, a NGO



**Ms. Diviya Chanana**  
Age: 51 years  
Graduate & holds  
Diploma in Travel and  
Tourism

She is Executive Director of Damus Travels Private Limited. The Company is engaged in supporting and auxiliary transport activities; activities of travel agencies



**Mr. Arun Malhotra**  
Age: 63 years  
B.E Mechanical &  
MBA from IIM,  
Kolkata

He is an Indian automotive sector veteran, his last assignment was as the Managing Director of Nissan India and thereafter as Senior Corporate Advisor at Nissan India. He has over 30 years of experience with organization like Escorts, Bajaj Auto Ltd, and Maruti Suzuki India Ltd



**Mr. A P Gandhi**  
Age: 83 years  
Mechanical Engineer

He has held top leadership positions in prestigious organisations such as President at Hyundai Motors India Limited , Chief Executive – R&D at Escorts Limited & at Telco and having over 40 years of experience.

# Professional & Experienced Team



Mr. Sanjay Mehta  
Director & Group CFO  
Age: 54 years  
Experience: 29 Years



Mr. Vikas Marwah  
Chief Executive Officer  
Age: 54 years  
Experience: 30 Years



Mr. Naval Khanna  
Corporate Head –  
Taxation  
Age: 63 years  
Experience: 43 years



Mr. Raajesh Gupta  
Group Company Secretary  
Age: 51 Years  
Experience: 28 Years



Mr. Sanjay Bhagat  
Head After Market  
Age: 54 years  
Experience: 29 years



Mr. Atul Jain  
Corporate Head -  
Materials  
Age: 52 years  
Experience: 29 Years



Mr. Rajesh Dubbewar  
Head Metallic  
Age: 53 years  
Experience: 30+ years



Ms. Priyanka Sharma  
Corporate  
Communication  
Age: 53 Years  
Experience: 26 Years



Mr Anil Tyagi  
Company Secretary  
Age: 49 years  
Experience: 22 years



Mr. Ashish Dubey  
Chief Financial Officer  
Age: 53 years  
Experience: 29 Years



# Financial Performance



# Product-wise Revenue Break-Up

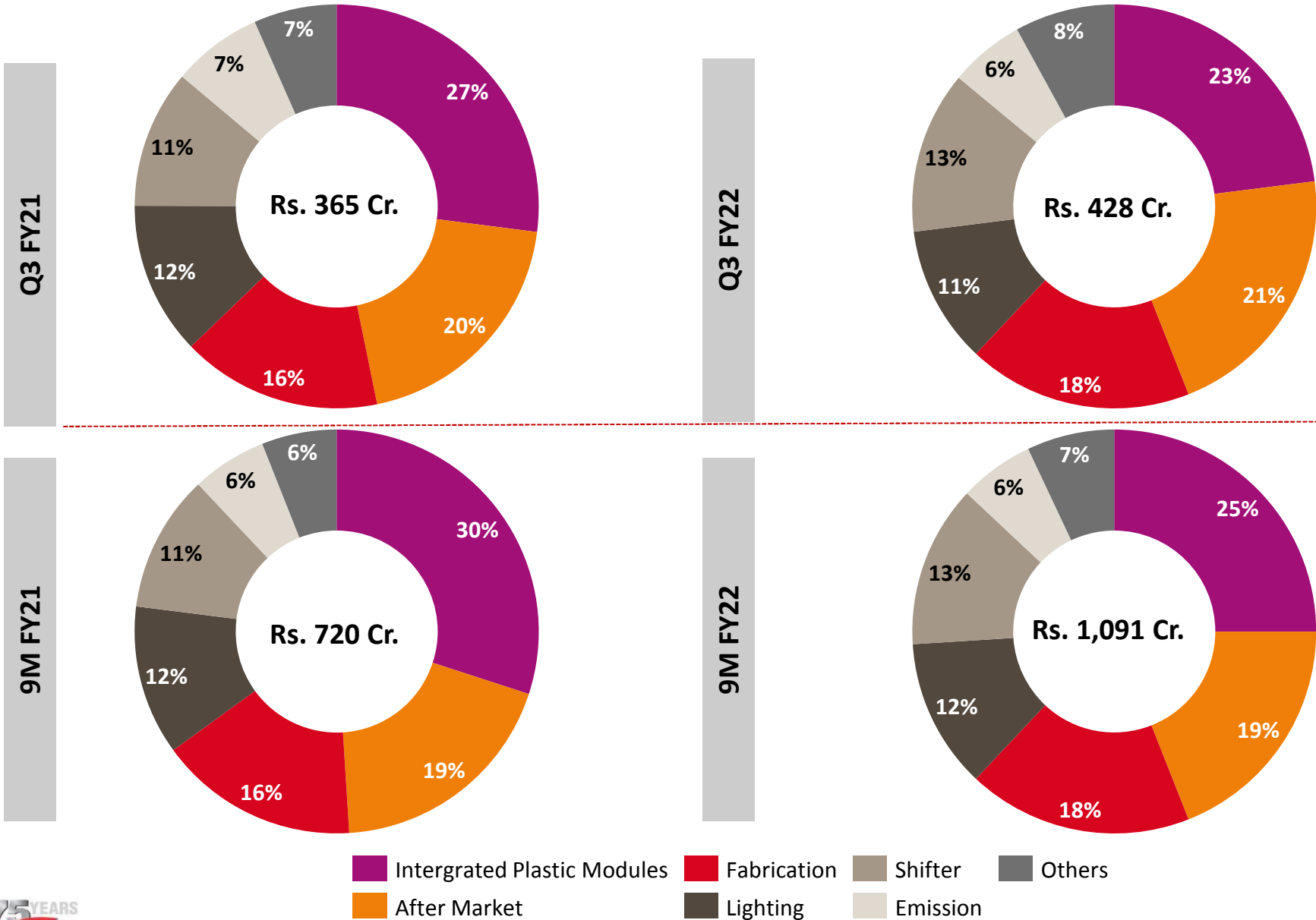

# Segmental Revenue Break-Up: Category

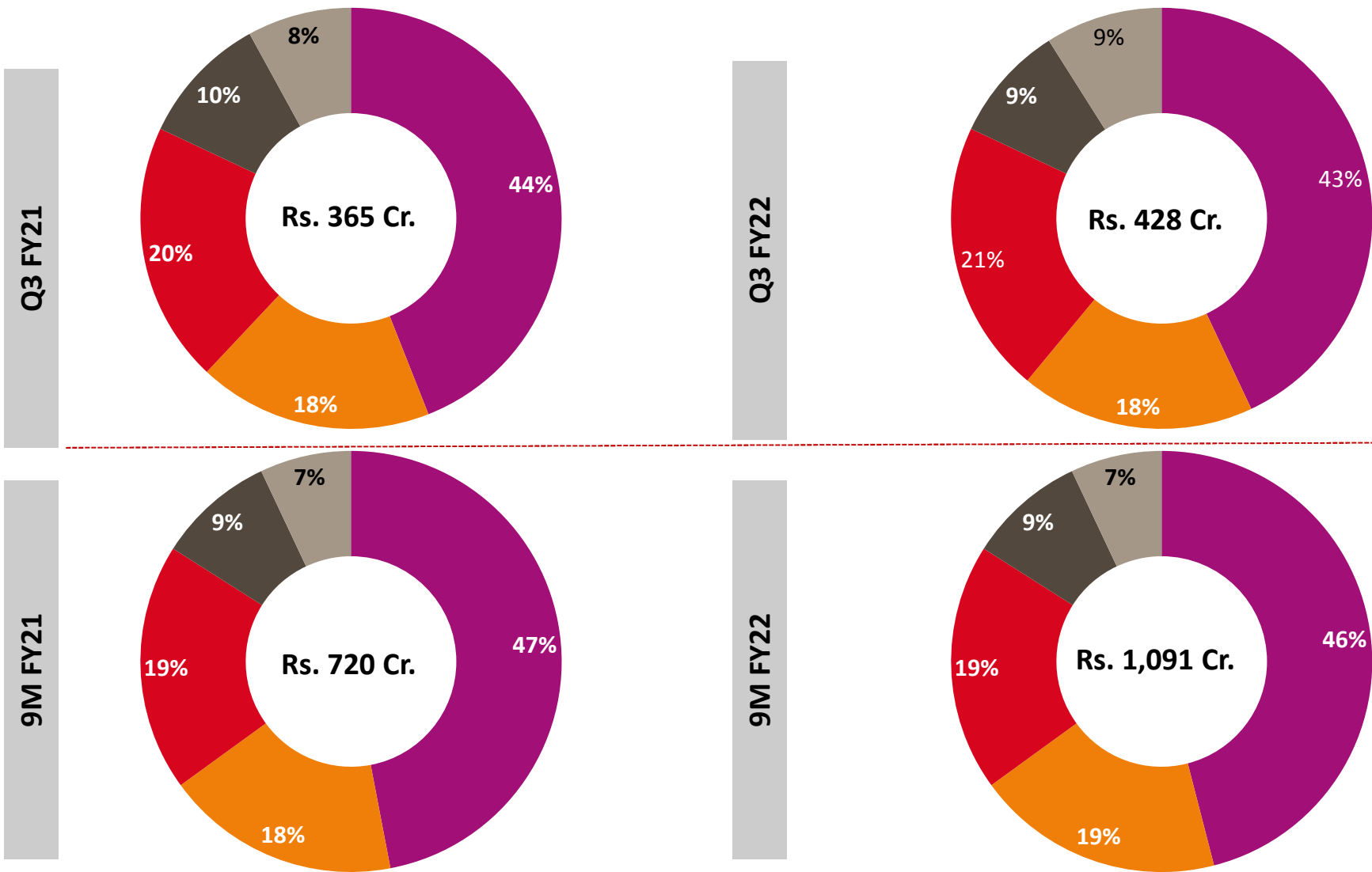

■ 2/3 Wheeler 
 ■ Passenger Car 
 ■ After Market 
 ■ CV 
 ■ Others



# Customer wise – Revenue Break-Up

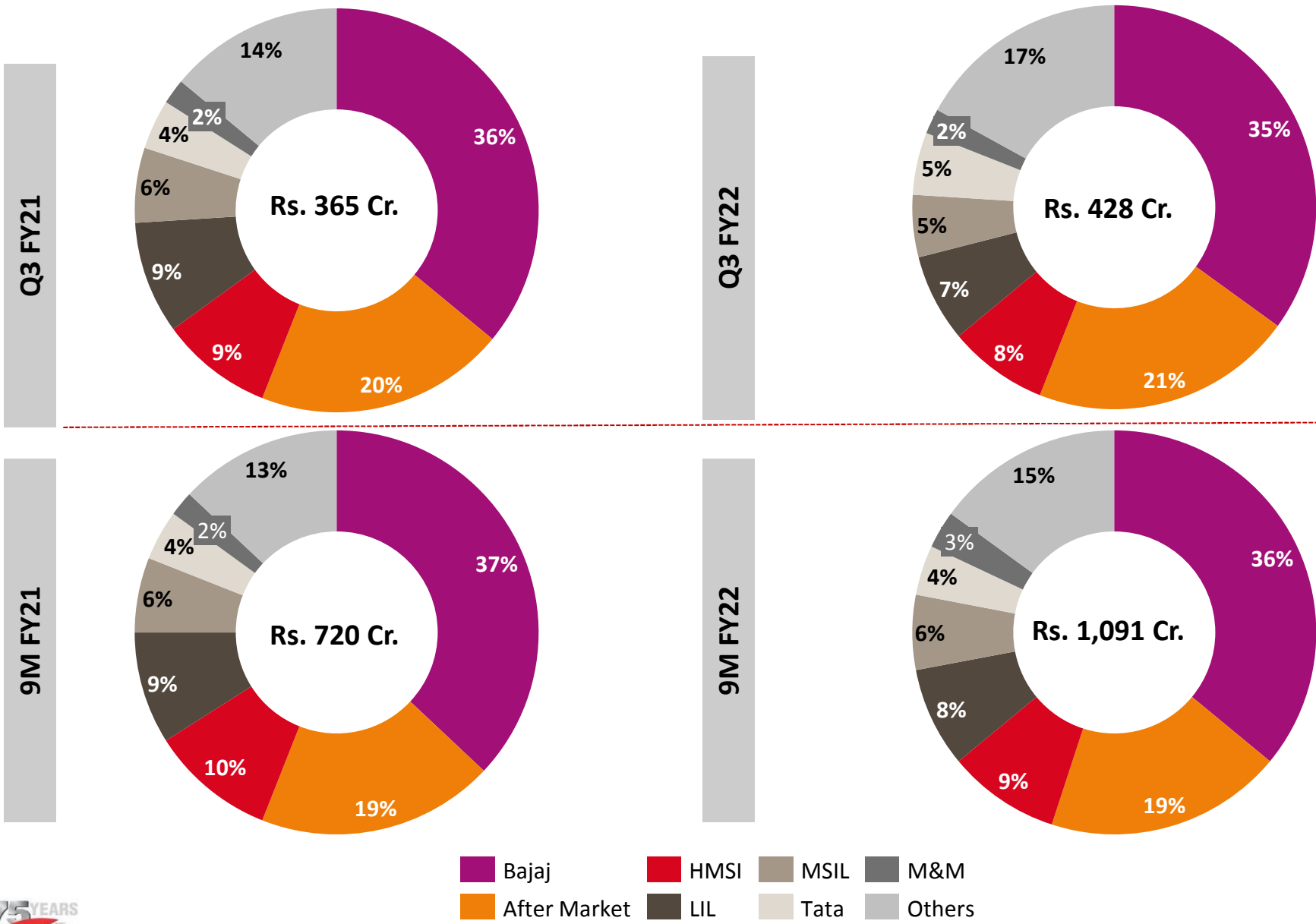

# Strong historical financial performance



## Revenue

Rs. Crores

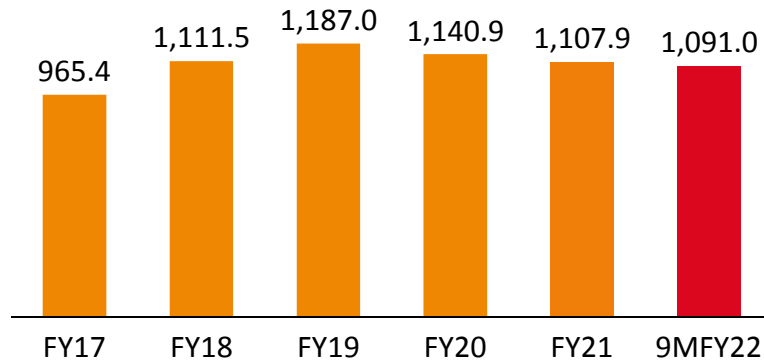

## EBITDA<sup>^</sup>

Rs. Crores

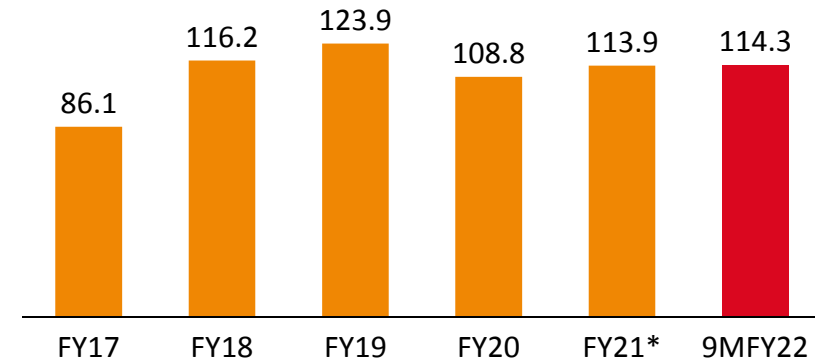

## PAT After MI

Rs. Crores

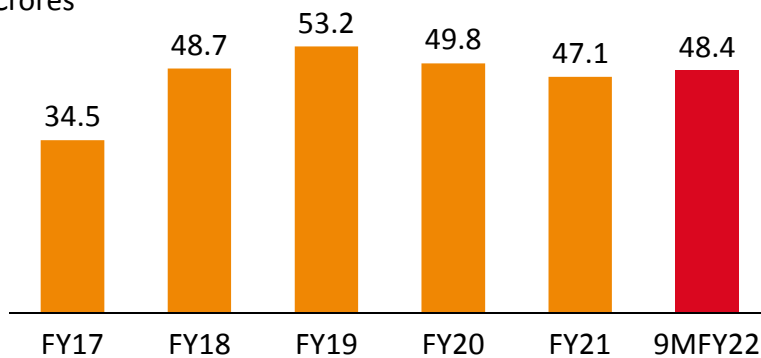

## Cash PAT

Rs. Crores

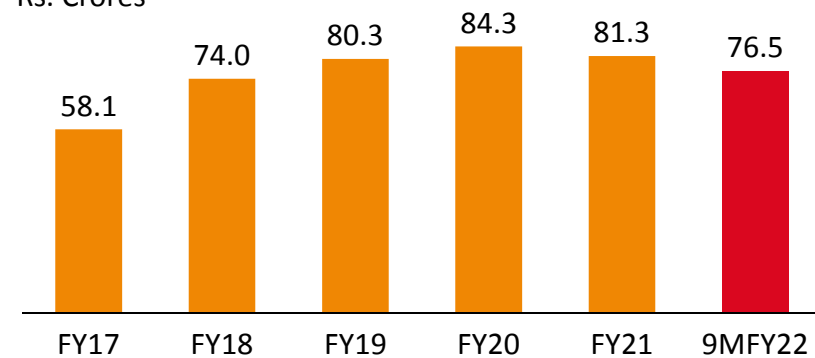

Consolidated

<sup>^</sup>EBITDA includes share of profits from JV's & other income

\* FY21 EBITDA: Excluding gain on sale of property – Rs. 2.22 crores excluded from Other Income





# Expansion funded through Internal Accruals



### Gross Block

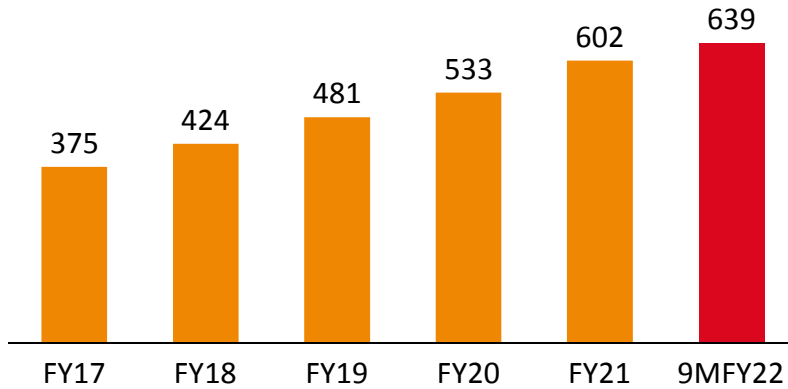

### Long Term Loan

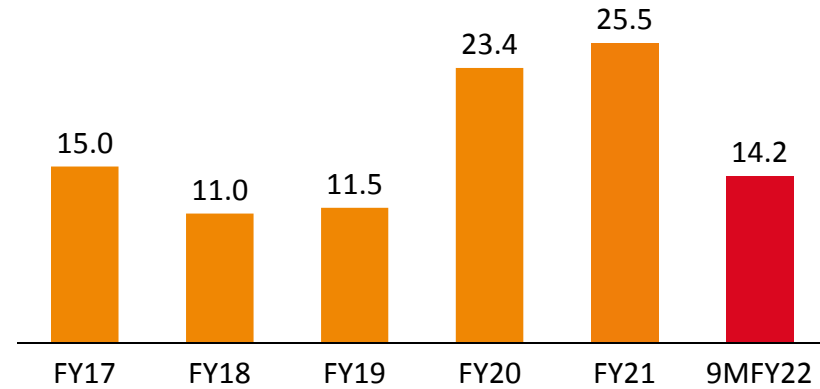

### Capex

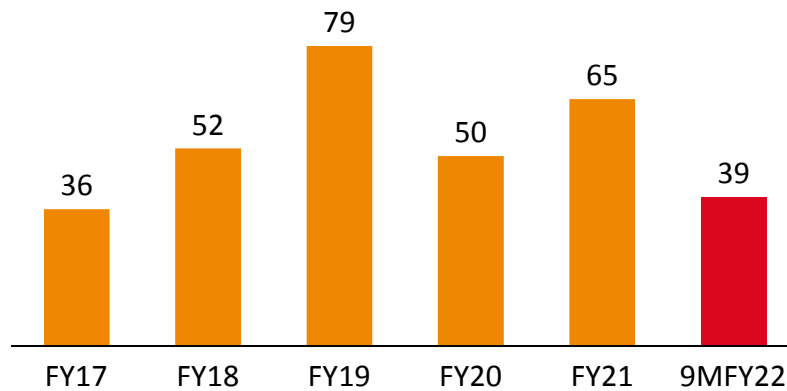

### Long Term Debt / Equity

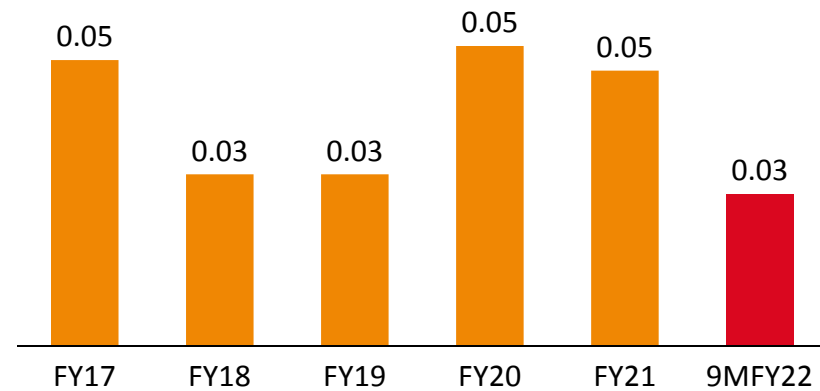

# Return Ratios



### ROE (%)

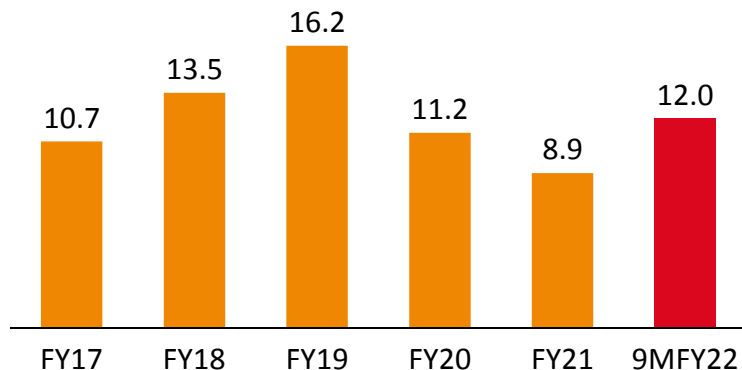

### ROCE (%)

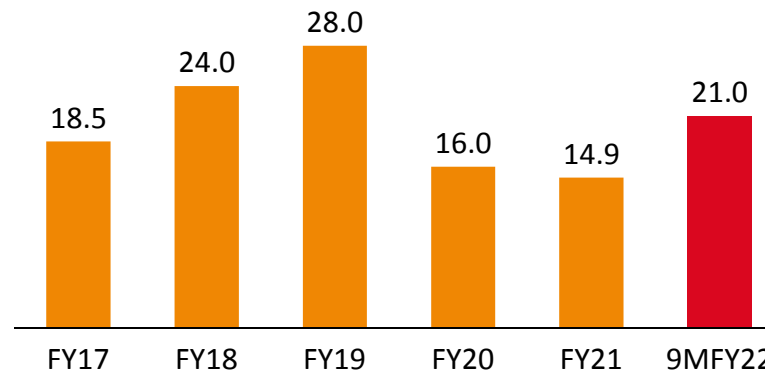

### Dividend (% of Face Value)

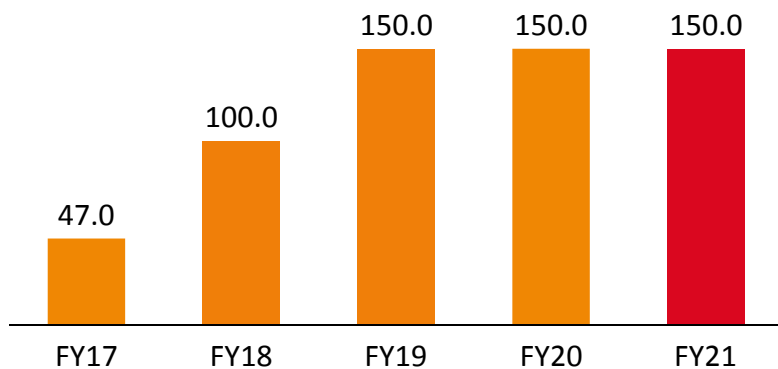

### EPS^ (in Rs.)

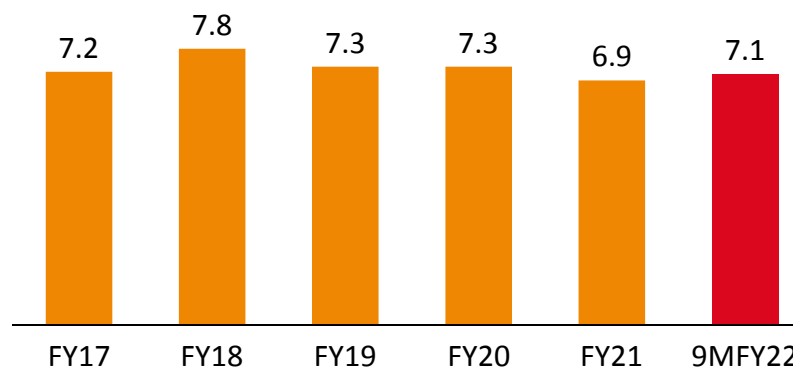

Consolidated

^ EPS on FV of Rs. 2 per share

ROCE = EBIT / Capital Employed

Capital Employed = Networth + Long Term Debt including Current Maturity

Networth = Shareholder's Equity – OCI Reserve



# Consolidated P&L Statement



Particulars (Rs. in Crores.)	Q3 FY22	Q3 FY21	Y-o-Y	9M FY22	9M FY21	Y-o-Y
<b>Revenue</b>	<b>427.6</b>	<b>365.2</b>	<b>17%</b>	<b>1091.0</b>	<b>719.9</b>	<b>52%</b>
Raw Material Consumption	293.9	248.1		743.3	486.6	
Employee Expenses	42.7	38.4		122.1	92.1	
Other Expenses	45.8	40.8		119.7	85.9	
Other Income	2.9	4.6		8.9	12.0	
Profit of JV	-0.1	-0.03		-0.6	0.05	
<b>EBITDA</b>	<b>47.8</b>	<b>42.6</b>	<b>12%</b>	<b>114.3</b>	<b>67.3</b>	<b>70%</b>
<b>EBITDA %</b>	<b>11.2%</b>	<b>11.7%</b>		<b>10.5%</b>	<b>9.3%</b>	
Depreciation	10.2	9.0		28.1	25.0	
Finance Cost	2.2	2.2		6.6	7.8	
<b>Profit Before Tax (Before Exceptional Items)</b>	<b>35.4</b>	<b>31.3</b>	<b>13%</b>	<b>79.5</b>	<b>34.5</b>	<b>131%</b>
Tax	10.0	8.2		22.9	10.4	
<b>Profit After Tax (Before Minority Interest)</b>	<b>25.4</b>	<b>25.4</b>	<b>0%</b>	<b>56.6</b>	<b>26.3</b>	<b>115%</b>
Minority Interest	3.8	2.3		8.2	0.2	
<b>Adjusted Profit After Tax</b>	<b>21.6</b>	<b>23.1</b>	<b>-7%</b>	<b>48.4</b>	<b>26.1</b>	<b>85%</b>
<b>PAT Margin%</b>	<b>5.0%</b>	<b>6.3%</b>		<b>4.4%</b>	<b>3.6%</b>	
<b>EPS</b>	<b>3.16</b>	<b>3.39</b>		<b>7.10</b>	<b>3.83</b>	

# Consolidated Balance Sheet



ASSETS (Rs. in Crores.)	Sep-21	Mar-21	EQUITY & LIABILITIES	Sep-21	Mar-21
<b>Non-current assets</b>			<b>Equity</b>		
Property, plant and equipment	330.4	331.5	Equity Share capital	13.6	13.6
Capital work-in-progress	13.8	9.3	Non-Controlling Interest	43.4	40.4
Investment Property	12.8	17.6	Other equity	514.7	517.1
Right-to-use asset	36.2	28.1			
Goodwill	0.2	0.2	<b>Sub-total - Shareholders' funds</b>	<b>571.7</b>	<b>571.1</b>
Other Intangible assets	3.0	3.3	<b>LIABILITIES</b>		
Investment in Jointly controlled Entities	1.6	1.0	<b>Non-current liabilities</b>		
<b>Financial assets</b>			<b>Financial liabilities</b>		
Investments	80.9	89.4	Borrowings	11.7	5.5
Loans	0.1	0.1	Lease Liability	28.1	18.7
Others	6.9	6.1	Provisions	6.6	6.3
Income Tax Assets	6.9	6.8	Deferred tax liabilities (net)	13.0	14.1
Other non-current assets	16.6	9.3	<b>Sub-total - Non-current liabilities</b>	<b>59.4</b>	<b>44.6</b>
Deferred Tax Assets (net)	0.01	0.1	<b>Current liabilities</b>		
<b>Sub-total - Non-Current Assets</b>	<b>509.5</b>	<b>502.9</b>	<b>Financial liabilities</b>		
<b>Current assets</b>			Borrowings	95.7	66.9
Inventories	99.2	83.6	Lease Liability	6.1	7.3
<b>Financial assets</b>			Trade payables	218.9	204.8
Loans	0.6	0.6	Other financial liabilities	33.1	32.6
Investments	41.0	40.3	Provisions	18.1	15.4
Trade receivables	250.7	223.0	Other current liabilities	63.6	44.4
Cash and cash equivalents	31.5	16.7	Current tax liabilities	4.1	2.7
Bank balances other than Cash	90.1	81.3	<b>Sub-total - Current liabilities</b>	<b>439.5</b>	<b>374.0</b>
Other Financial Assets	7.5	12.7	<b>TOTAL - EQUITY AND LIABILITIES</b>	<b>1070.7</b>	<b>989.7</b>
Other current assets	40.5	28.6			
Assets held for Sale	-	-			
<b>Sub-total - Current Assets</b>	<b>561.2</b>	<b>486.7</b>			
<b>TOTAL - ASSETS</b>	<b>1070.7</b>	<b>989.7</b>			



# Awards & Recognitions



## ACMA Awards



Lumax Mettalics Pvt Ltd won the **Gold Award** in Excellence in HSE Small Category at the **ACMA Technology Summit & Awards** in 2019



Lumax Mettalics Pvt Ltd, Pune won the **Gold Award** in the category Excellence in HSE – Small at the **ACMA Excellence Awards 2020** in 2021

# TPM Awards



Chakan Plant – Category B in 2017



Bengaluru plant – excellence in Category A for the year 2019

# Best Annual Report



Won the prestigious award for best annual report from League of American Communications Professionals (LACP) for excellence within its industry for the financial year 2018-19 & 2019-20



# Recognition



Lumax Mannoh Allied Technologies Ltd. received **first ever Patent registration from the Government of India for invention in “Shift Knob Assembly”** in January 2021



**Toyota Kirloskar Motor Pvt Ltd.** recognised the efforts and commitment of Lumax Mannoh Allied Technologies Limited towards providing timely and quality delivery to Toyota in 2020

# State-of-the-Art Manufacturing Facilities



# State-of-the-Art Manufacturing Facilities



# State-of-the-Art Manufacturing Facilities



## Social Initiatives by Lumax group towards 'Quality Education' for the society



# State-of-the-Art Manufacturing Facilities



Social Initiatives by Lumax group towards 'Good Health' for the society



**For further information, please contact:**

**Company:**

**Investor Relations Advisors:**



**Lumax Auto Technologies Limited**  
CIN: L31909DL1981PLC349793

Ms. Priyanka Sharma  
[priyanka.sharma@lumaxmail.com](mailto:priyanka.sharma@lumaxmail.com)

[www.lumaxworld.in/lumaxautotech](http://www.lumaxworld.in/lumaxautotech)



**Strategic Growth Advisors Pvt. Limited**  
CIN: U74140MH2010PTC204285

Mr. Shogun Jain / Ms. Akashi Modi  
[shogun.jain@sgapl.net](mailto:shogun.jain@sgapl.net) / [akashi.modi@sgapl.net](mailto:akashi.modi@sgapl.net)

Tel: +91 77383 77756 / +91 96198 96128  
[www.sgapl.net](http://www.sgapl.net)