



AM/STOEX-GN/74

6th August, 2019

| | |
|---|---|
| BSE Limited Phiroze Jeejeebhoy Towers Dalal Street Mumbai: 400 001 | National Stock Exchange of India Limited Exchange Plaza, 5th Floor Plot No. C/1, G Block Bandra Kurla Complex Bandra (East) Mumbai - 400 051 |
| Mr. Daniel Schammo Banque Internationale A Luxembourg Societe Anonyme 69, Route d'Esch L-2953 LUXEMBOURG Fax No. 00 352 4590 2010 TEL. NO. 00 352 4590-1 | |

Dear Sir,

Sub: Investor Presentation-Novelis Inc (Wholly Owned Subsidiary)

Please find enclosed herewith the Investor Presentation of our Wholly-owned Subsidiary i.e. Novelis Inc. for the First Quarter Fiscal Year 2020.

Thanking You

Yours faithfully,
For HINDALCO INDUSTRIES LIMITED

Anil Malik
President & Company Secretary

Encl: as above

NOVELIS Q1 FISCAL 2020 EARNINGS CONFERENCE CALL

August 6, 2019

Steve Fisher

President and Chief Executive Officer

Dev Ahuja

Senior Vice President and Chief Financial Officer

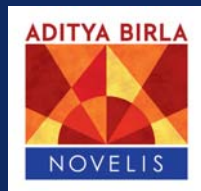

Novelis

Forward-looking statements

Statements made in this presentation which describe Novelis' intentions, expectations, beliefs or predictions may be forward-looking statements within the meaning of securities laws. Forward-looking statements include statements preceded by, followed by, or including the words "believes," "expects," "anticipates," "plans," "estimates," "projects," "forecasts," or similar expressions. Examples of forward looking statements in this news release are statements about our expectation that the proposed Aleris acquisition will close in the fourth quarter of this year. Novelis cautions that, by their nature, forward-looking statements involve risk and uncertainty and Novelis' actual results could differ materially from those expressed or implied in such statements. We do not intend, and we disclaim any obligation, to update any forward-looking statements, whether as a result of new information, future events or otherwise. Factors that could cause actual results or outcomes to differ from the results expressed or implied by forward-looking statements include, among other things: changes in the prices and availability of aluminum (or premiums associated with such prices) or other materials and raw materials we use; the capacity and effectiveness of our hedging activities; relationships with, and financial and operating conditions of, our customers, suppliers and other stakeholders; fluctuations in the supply of, and prices for, energy in the areas in which we maintain production facilities; our ability to access financing including in connection with potential acquisitions and investments; risks relating to, and our ability to consummate, pending and future acquisitions, investments or divestitures, including the proposed acquisition of Aleris Corporation; changes in the relative values of various currencies and the effectiveness of our currency hedging activities; factors affecting our operations, such as litigation, environmental remediation and clean-up costs, labor relations and negotiations; breakdown of equipment and other events; economic, regulatory and political factors within the countries in which we operate or sell our products, including changes in duties or tariffs; competition from other aluminum rolled products producers as well as from substitute materials such as steel, glass, plastic and composite materials; changes in general economic conditions including deterioration in the global economy; changes in government regulations, particularly those affecting taxes, derivative instruments, environmental, health or safety compliance; changes in interest rates that have the effect of increasing the amounts we pay under our credit facilities and other financing agreements; and our ability to generate cash. The above list of factors is not exhaustive. Other important risk factors are included under the caption "Risk Factors" in our Annual Report on Form 10-K for the fiscal year ended March 31, 2019.

FIRST QUARTER HIGHLIGHTS

- Strong operational & financial performance
- Organic expansion projects progressing on time and on budget
- Increasing focus on delivering next-generation automotive aluminum solutions
 - Sheet-intensive battery enclosures
 - High-strength, lightweight 6HS-s650 alloy for structural applications
- Digital transformation underway to drive world class manufacturing operations

Trailing Twelve Month ending June 30 Adjusted EBITDA
(\$ millions)

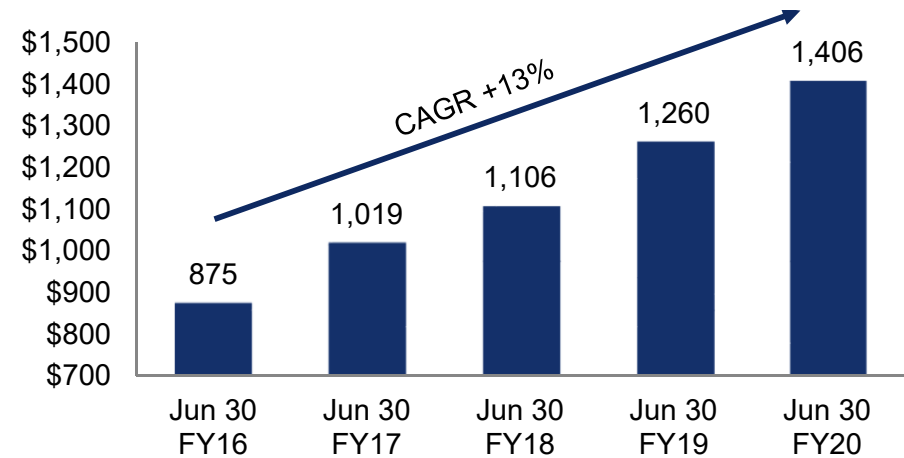

Novelis Advanz™ 6HS-s650 potential applications

1. Rocker
2. Tunnel
3. Floor panel
4. Bumpers
5. A pillar Reinforcement
6. Roof rail inserts
7. B pillar Reinforcement
8. Anti intrusion beam

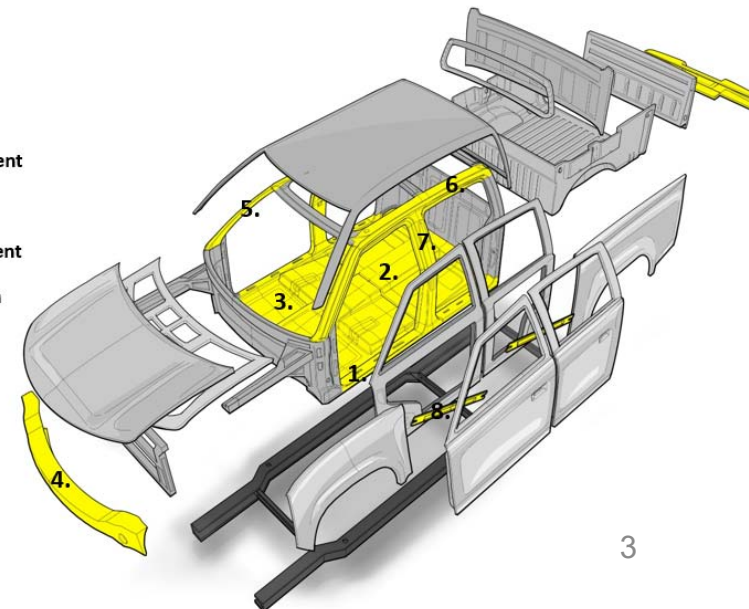

Beverage Can

- Demand trends strong globally
- Growth in emerging markets
- Package mix shift from other substrates to aluminum
- New beverage types released in aluminum
- Rising consumer preference favors aluminum sustainable package

Automotive

- Exposure to trucks, SUVs, electric & premium vehicles
- North America market remains strong
- Broad aluminization trend throughout Europe
- Some challenges in Europe due to exposure to one large customer
- Trade war/weak consumer confidence in China

Specialties

- Strong demand in North America
- Increasing competition with Chinese imports in regions outside U.S.
- Novelis capacity constraints create opportunities for portfolio optimization

- Continue to work through regulatory and closing process
- Expected to close the transaction in the fourth quarter of calendar 2019, subject to customary closing conditions and regulatory approvals
- Commitment to Net Debt/Adjusted EBITDA forecasted to peak below 4x at close; return to 3x within two years

Novelis



FINANCIAL HIGHLIGHTS

Q1 FISCAL 2020 FINANCIAL HIGHLIGHTS

Q1FY20 vs Q1FY19

- Net income of \$127 million
 - Excluding tax-effected special items*, net income of \$145 million compared to \$115 million in the prior year
- Adjusted EBITDA up 11% from \$334 million to \$372 million
- Adjusted EBITDA per ton up 7% to \$448
- Sales down 6% to \$2.9 billion on lower LME prices
- Total FRP Shipments up 4% to 830 kilotonnes

Quarterly Adjusted EBITDA (\$ millions)

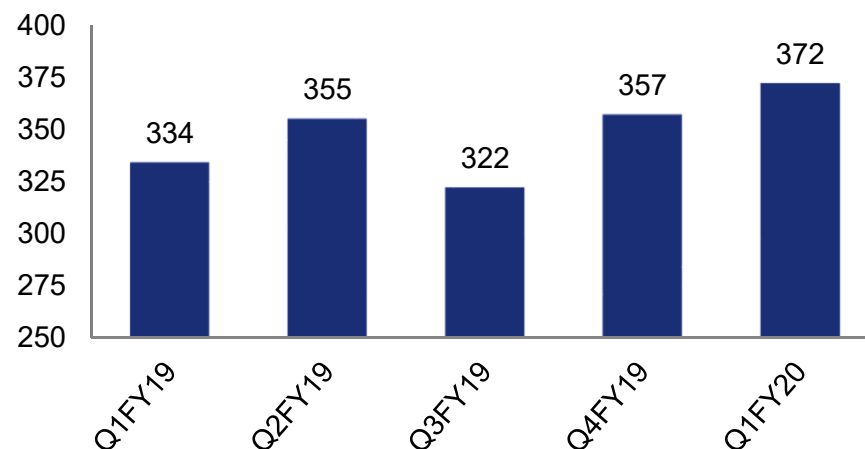

Quarterly Adjusted EBITDA per ton (\$)

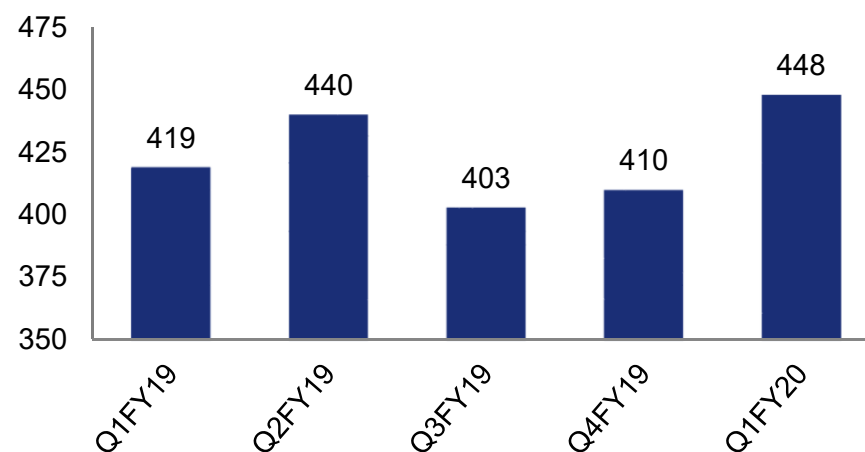

Q1 ADJUSTED EBITDA BRIDGE

\$ Millions

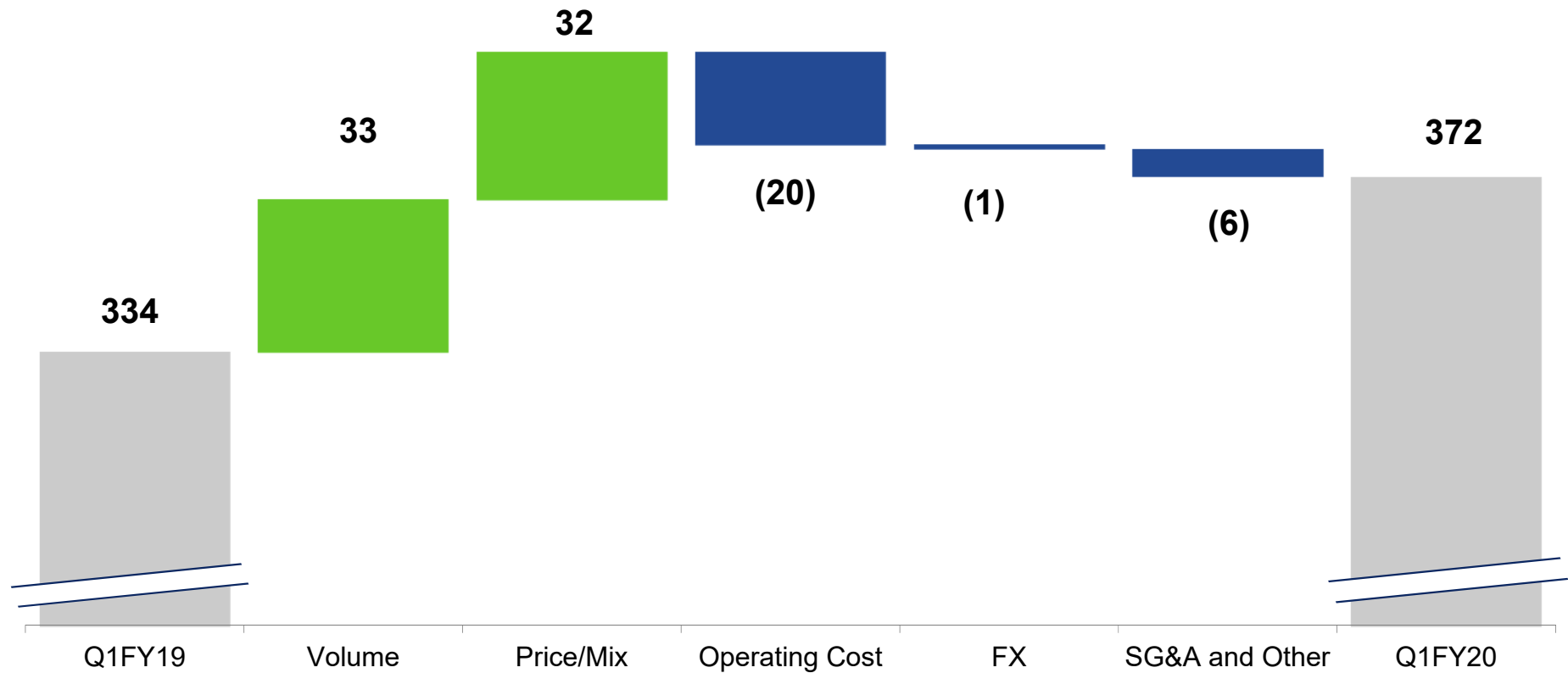

Strong operational performance in favorable market conditions

FREE CASH FLOW AND NET LEVERAGE

| \$ Millions | Q1 FY20 | Q1 FY19 |
|------------------------------------|-------------|------------|
| Adjusted EBITDA | 372 | 334 |
| Interest paid | (64) | (65) |
| Taxes paid | (40) | (41) |
| Working capital & other | (200) | (178) |
| Free cash flow before CapEx | 68 | 50 |
| Capital expenditures | (162) | (54) |
| Free cash flow | (94) | (4) |

Prior period is adjusted to conform to current presentation

Net Leverage ratio
Net debt/TTM Adjusted EBITDA

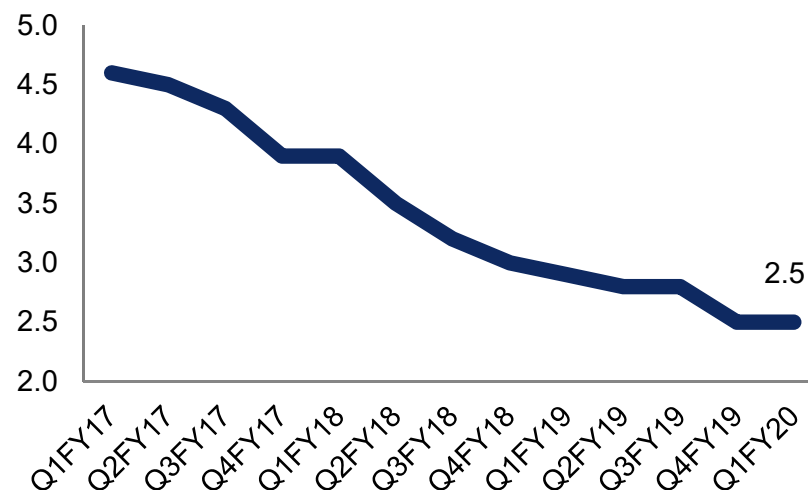

- Free cash flow before capital expenditures increased 36%
 - Higher adjusted EBITDA
 - Lower working capital from lower aluminum prices and inventory
 - Offsetting factors include prior year \$33 million metal price lag benefit and other non-operational items
- Capital expenditures tripled YoY, primarily to support strategic capacity expansions
- Strong liquidity of \$1.7 billion
- Net leverage ratio of 2.5x

STRATEGIC CAPACITY INVESTMENTS ON TRACK

- Organic expansions progressing on time and on budget
- Construction is well underway with all three significant projects
 - 200kt greenfield automotive finishing lines in the U.S. to begin customer qualification late FY20
 - 100kt automotive finishing expansion in China commissioning in FY21
 - 100kt rolling and 60kt recycling expansion in Brazil commissioning in FY21

Guthrie, Kentucky, US



Changzhou, China



Pinda, Brazil

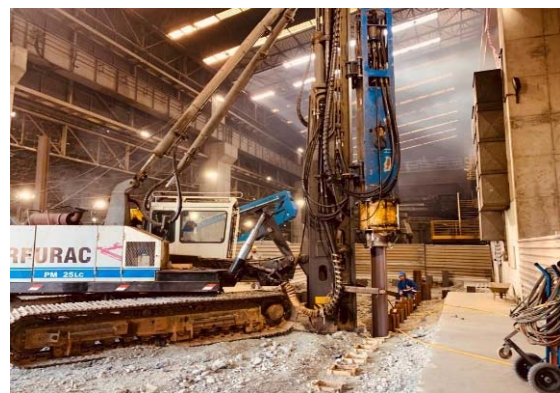

SUMMARY

- Delivering high-quality, sustainable, innovative products to customers in broadly positive market conditions for the near and long term
- Continued focus on optimizing manufacturing operations and product portfolio to maximize existing capacity in favorable market conditions
- Strategic investments to diversify our product portfolio and strengthen our business for the long term are on track
- Continue working with regulatory agencies to close the Aleris transaction in a timely manner



THANK YOU
QUESTIONS?

APPENDIX

NET INCOME RECONCILIATION TO ADJUSTED EBITDA

| (in \$ m) | Q1 | Q2 | Q3 | Q4 | FY19 | Q1 FY20 |
|---|--------------|--------------|--------------|--------------|----------------|--------------|
| Net income attributable to our common shareholder | 137 | 116 | 78 | 103 | 434 | 127 |
| - Noncontrolling interests | - | - | - | - | - | - |
| - Income tax provision | 53 | 64 | 37 | 48 | 202 | 63 |
| - Interest, net | 63 | 66 | 64 | 65 | 258 | 62 |
| - Depreciation and amortization | 86 | 86 | 88 | 90 | 350 | 88 |
| EBITDA | 339 | 332 | 267 | 306 | 1,244 | 340 |
| - Unrealized (gain) loss on derivatives | 4 | (1) | 6 | 1 | 10 | (6) |
| - Realized (gain) loss on derivative instruments not included in segment income | - | (1) | - | (1) | (2) | 2 |
| - Proportional consolidation | 16 | 15 | 14 | 13 | 58 | 15 |
| - (Gain) loss on sale of fixed assets | 3 | (1) | 2 | 2 | 6 | (1) |
| - Restructuring and impairment, net | 1 | - | 1 | - | 2 | 1 |
| - Metal price lag (income) expense | (33) | (1) | 13 | 25 | 4 | 2 |
| - Business acquisition and other integration costs (A) | 2 | 8 | 14 | 9 | 33 | 17 |
| - Other, net | 2 | 4 | 5 | 2 | 13 | 2 |
| Adjusted EBITDA | \$334 | \$355 | \$322 | \$357 | \$1,368 | \$372 |

(A) Effective in the first quarter of fiscal 2019, management removed the impact of business acquisition and other integration costs from Adjusted EBITDA in order to enhance the visibility of the underlying operating performance of the Company. The impact of "Business acquisition and other integration costs", which are costs, primarily legal and professional fees, presented above associated with our proposed acquisition of Aleris, is now reported as a separate line item in this reconciliation and on our condensed consolidated statement of operations. Management reclassified \$2 million for the three months ending 6/30/18 from SG&A to "Business acquisition and other integration costs". This change in presentation does not impact our condensed consolidated financial statements.

FREE CASH FLOW AND LIQUIDITY

| | (in \$ m) | Q1 | Q2 | Q3 | Q4 | FY19 | Q1 FY20 |
|---|-----------|--------------|--------------|-------------|--------------|--------------|---------------|
| Cash provided by (used in) operating activities | | 48 | 162 | 114 | 404 | 728 | 57 |
| Cash provided by (used in) investing activities | | (52) | (291) | (91) | (123) | (557) | (149) |
| Plus: Cash used in the acquisition of assets under a capital lease | | - | 239 | - | - | 239 | - |
| Less: (proceeds) outflows from sale of assets, net of transaction fees, cash income taxes and hedging | | - | (2) | - | - | (2) | (2) |
| Free cash flow | | \$(4) | \$108 | \$23 | \$281 | \$408 | \$(94) |
| Capital expenditures | | 54 | 60 | 96 | 141 | 351 | 162 |

"Free cash flow" consists of: (a) "net cash provided by (used in) operating activities," (b) plus "net cash provided by (used in) investing activities" (c) plus cash used in the "Acquisition of assets under a capital lease", and (d) less "proceeds from sales of assets and business, net of transaction fees, cash income taxes and hedging". All prior periods presented conform to the presentation adopted for the current period.

| | (in \$ m) | Q1 | Q2 | Q3 | Q4 | FY19 | Q1 FY20 |
|--|-----------|----------------|----------------|----------------|----------------|----------------|----------------|
| Cash and cash equivalents | | 853 | 829 | 797 | 950 | 950 | 859 |
| Availability under committed credit facilities | | 1,059 | 907 | 884 | 897 | 897 | 870 |
| Liquidity | | \$1,912 | \$1,736 | \$1,681 | \$1,847 | \$1,847 | \$1,729 |