



## Jamna Auto Industries Ltd.

February 07, 2024

To,  
BSE Limited  
Exchange Plaza, Plot No. C/1, G- Block,  
Phiroze Jeejeebhoy Towers, Dalal Street,  
Mumbai- 400001 Maharashtra  
**BSE Code: 520051**

To,  
National Stock Exchange of India Limited  
Exchange Plaza, Plot no. C/1, G Block,  
Bandra-Kurla Complex, Bandra (E)  
Mumbai - 400 051, Maharashtra  
**NSE Code: JAMNAAUTO**

**Subject: Investors Presentation on the financial results for the quarter and nine months ended December 31, 2023.**

Dear Sir/Madam,

Pursuant to the requirements of Regulation 30 and Regulation 46 of SEBI (Listing Obligations & Disclosure Requirements) Regulations, 2015, we are enclosing herewith the presentation by the Company pertaining to the financial results for the quarter and nine months ended December 31, 2023.

Kindly take the above information on records

Thanking you,  
Yours faithfully,  
**For Jamna Auto Industries Limited**

**Praveen Lakhera**  
**Company Secretary & Head-Legal**



# Jamna Auto Industries Limited

Investor Presentation

Q3 FY 23-24



This presentation and the accompanying slides (the “Presentation”), have been prepared by Jamna Auto Industries Limited (the “Company”), have been prepared solely for information purposes and do not constitute any offer, recommendation or invitation to purchase or subscribe for any securities, and shall not form the basis or be relied on in connection with any contract or binding commitment whatsoever. No offering of securities of the Company will be made except by means of a statutory offering document containing detailed information about the Company.

This Presentation has been prepared by the Company based on information and data which the Company considers reliable, but the Company makes no representation or warranty, express or implied, whatsoever, and no reliance shall be placed on, the truth, accuracy, completeness, fairness and reasonableness of the contents of this Presentation. This Presentation may not be all inclusive and may not contain all of the information that you may consider material. Any liability in respect of the contents of, or any omission from, this Presentation is expressly excluded.

Certain matters discussed in this Presentation may contain statements regarding the Company’s market opportunity and business prospects that are individually and collectively forward-looking statements. Such forward-looking statements are not guarantees of future performance and are subject to known and unknown risks, uncertainties and assumptions that are difficult to predict. These risks and uncertainties include, but are not limited to, the performance of the Indian economy and of the economies of various international markets, the performance of the industry in India and world-wide, competition, the company’s ability to successfully implement its strategy, the Company’s future levels of growth and expansion, technological implementation, changes and advancements, changes in revenue, income or cash flows, the Company’s market preferences and its exposure to market risks, as well as other risks. The Company’s actual results, levels of activity, performance or achievements could differ materially and adversely from results expressed in or implied by this Presentation. The Company assumes no obligation to update any forward-looking information contained in this Presentation. Any forward-looking statements and projections made by third parties included in this Presentation are not adopted by the Company and the Company is not responsible for such third party statements and projections.





Q3 FY 23-24  
Financial Updates

# Financial Trends - QoQ



All figures are in INR crores

	Q3 FY 23-24	Q2 FY 23-24	Q3 FY 22-23
NET SALES	604	607	591
EBITDA	87/14.5%	81/13.3%	67/11.3%
PBT	74/12.2%	69/11.3%	56/9.5%
CASH ACCRUALS	67	61	51

Cash Accruals: PAT+ Depreciation

# Financial Trends - YoY



All figures are in INR crores

	9 Months FY 23-24	9 Months FY 22-23	FY 22-23
NET SALES	1,786	1,691	2,325
EBITDA	242/13.5%	191/11.3%	273/11.7%
PBT	205/11.5%	159/9.4%	229/9.9%
CASH ACCRUALS	185	146	209

Cash Accruals: PAT+ Depreciation

# Profit & Loss Statement



## Consolidated QoQ

All figures are in INR crores

Particulars	Q3 FY 23-24	Q3 FY 22-23	YoY	Q2 FY 23-24	QoQ
Net Sales	604	591	2%	607	-1%
EBITDA	87	67	31%	81	8%
PBT	74	56	32%	69	7%
PAT	55	41	34%	50	10%

# Profit & Loss Statement



## Consolidated YoY

All figures are in INR crores

Particulars	9 Months FY 23-24	9 Months FY 22-23	YoY	12 Months FY 22-23
Net Sales	1,786	1,691	2%	2,325
EBITDA	242	191	31%	273
PBT	205	159	32%	230
PAT	151	116	34%	168



# Revenue Mix

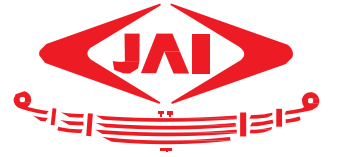

## Product Mix

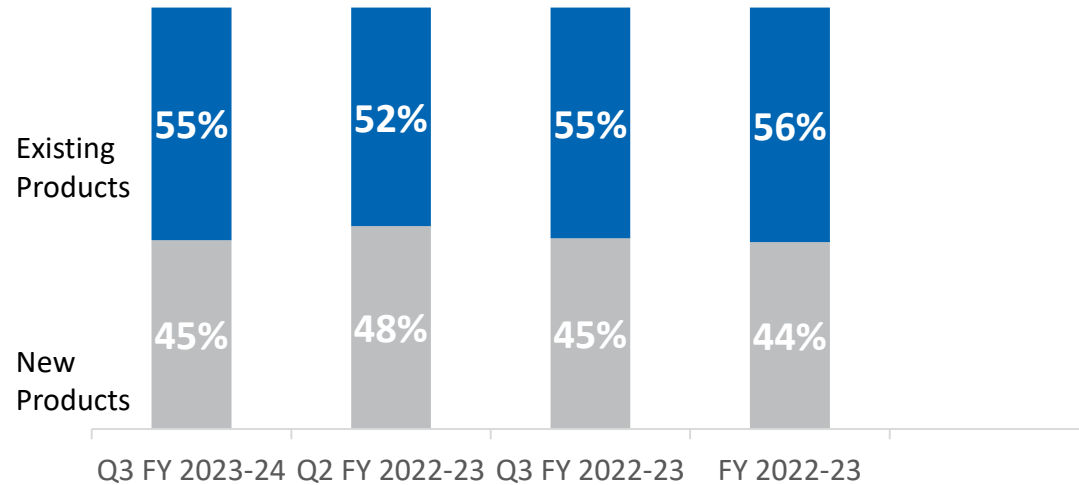

Lakshya Target: **50%** revenue from New Products by FY 2026-27

## Market Mix

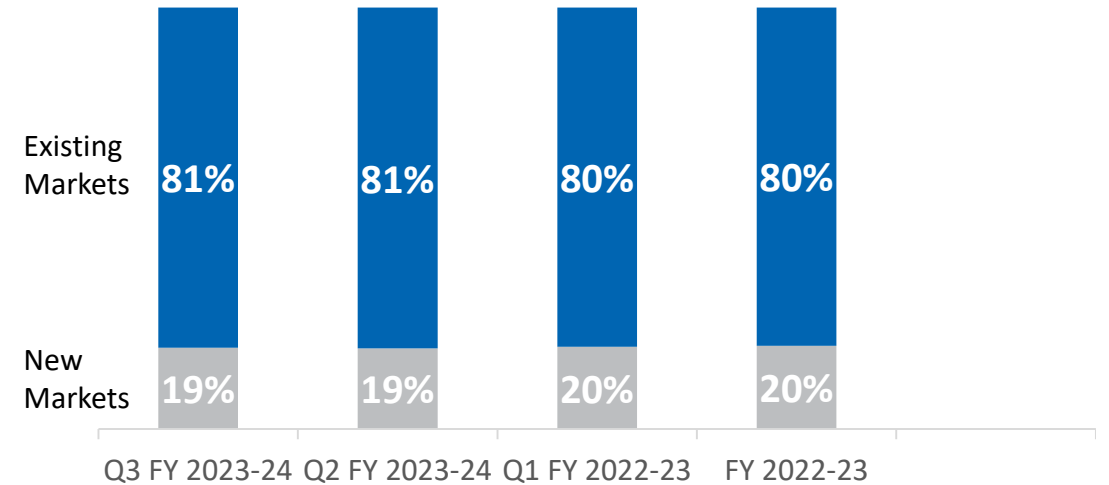

Lakshya Target: **50%** revenue from New Markets by FY 2026-27



# Industry Highlights

# Industry Highlights



All figures are in '000

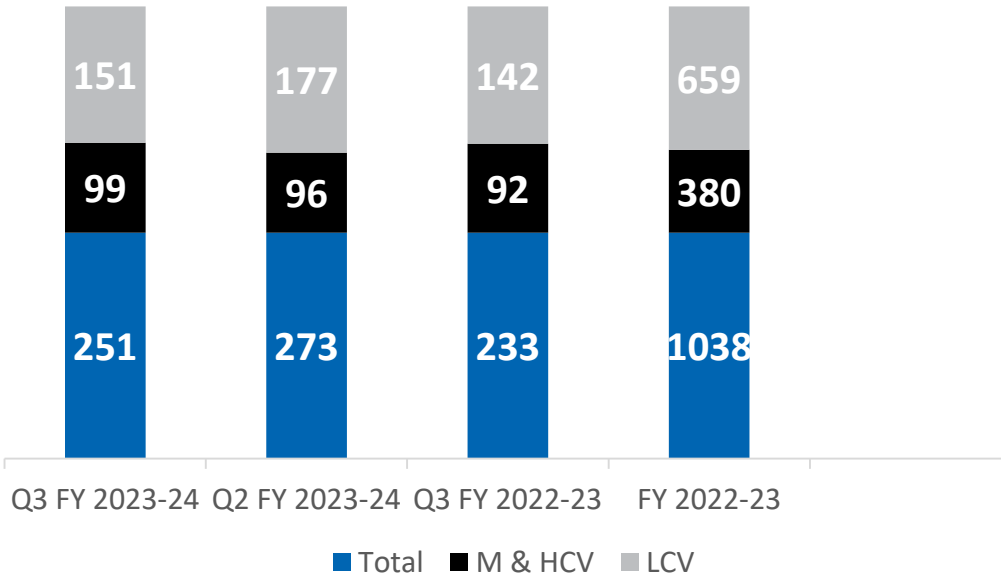

Data Source-SIAM

## CV production changes

- ↓ - Q3 FY24 vs Q2 FY24 - 15% (Decrease)
- ↑ - Q3 FY24 vs Q3 FY23 - 7% Increase

## M&HCV production changes

- ↑ - Q3 FY24 vs Q2 FY24 - 3% Increase
- ↑ - Q3 FY24 vs Q3 FY23 - 9% Increase

For the Quarter

QoQ Change %	YoY Change %
-15%	7%
3%	9%
-8%	8%





Company  
Overview

# JAI at a Glance



**Foundation**  
JAI is a renowned suspension manufacturer for commercial vehicles.

**World class Manufacturing Infrastructure**  
10 Manufacturing units including 1 In-house R&D center

- More than 16,000 touch points
- JAI Shoppe in Sanjay Gandhi Transport Nagar, Delhi which is one of the largest trucking center in India.

**Manufacturing**  
~300+ OEM parts  
~5,000+ AMI parts

**Sound Financials**  
CRISIL A1+/AA-

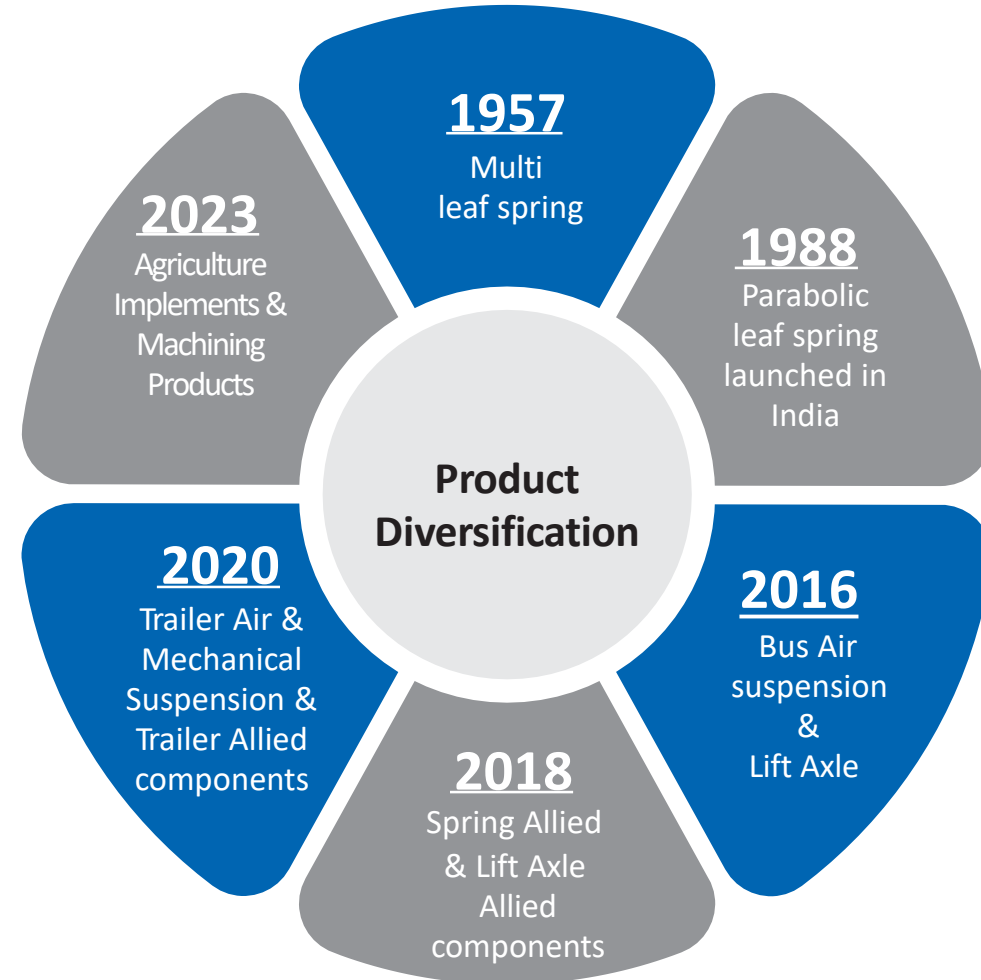

# Jai's Plants : Strategically Located Across OEM Plants

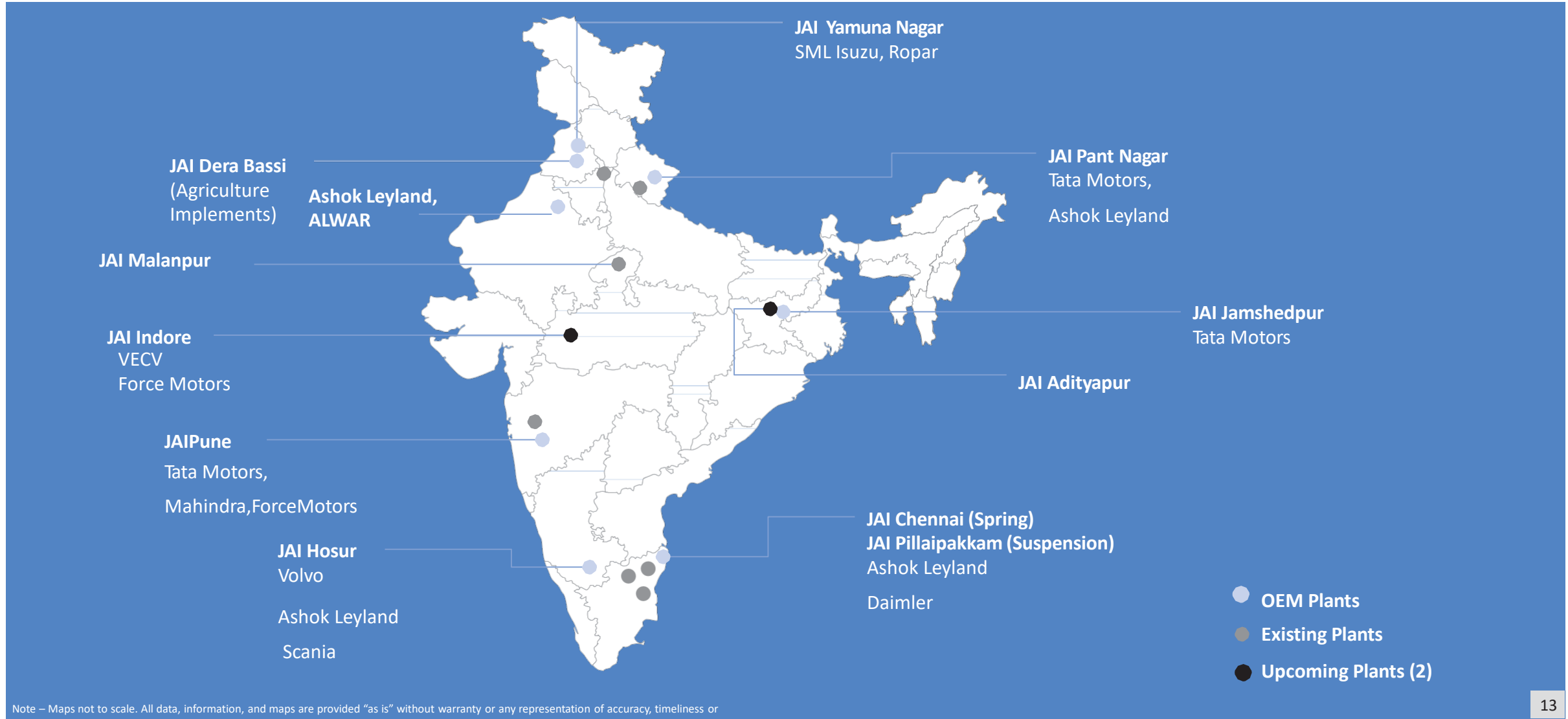



# Strength and Key Focus Areas

## Strength

- Manufacturing footprint with logistics benefit.
- Low BEP with Low Leveraged.
- Spare capacity to capture unprecedented demand from all Markets.
- Wide After Market Network  
300+ Distributors,  
11500+Retailers,  
15000+ Mechanics.



## Key Focus Areas

- New Markets ( AMI, AME).
- New Products ( Trailer, CPV in CV).

# JAI's OEM Customers



# JAI's Product Portfolio

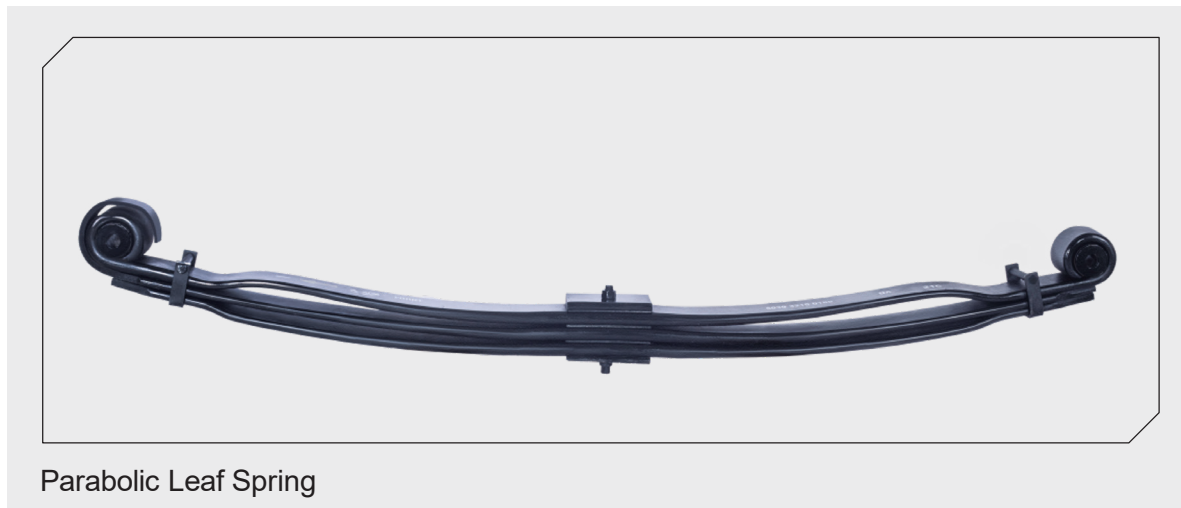
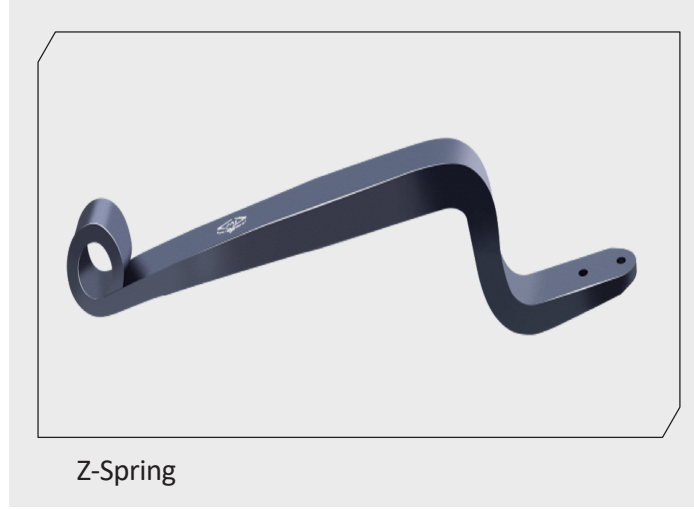

# JAI's Product Portfolio

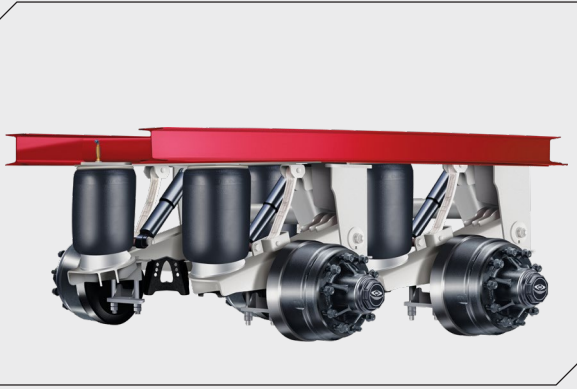

Bus Air Suspension

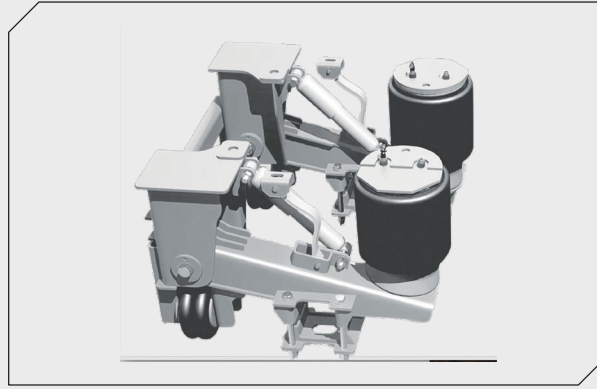

Trailer Air Suspension



Lift Axle

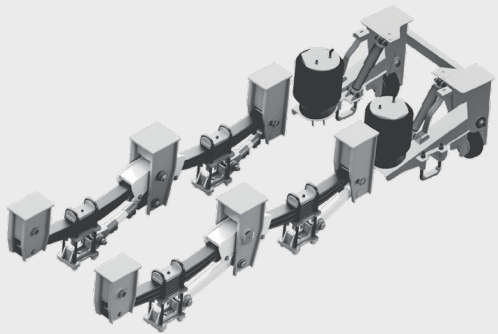

Trailer Mechanical and Air Suspension with Lift Axle

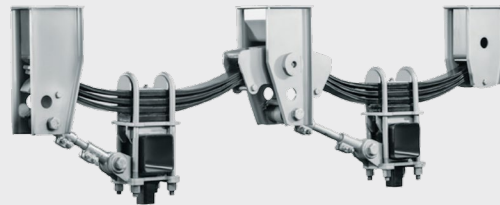

Trailer Mechanical Suspension

# After Market India JAI's Product Portfolio

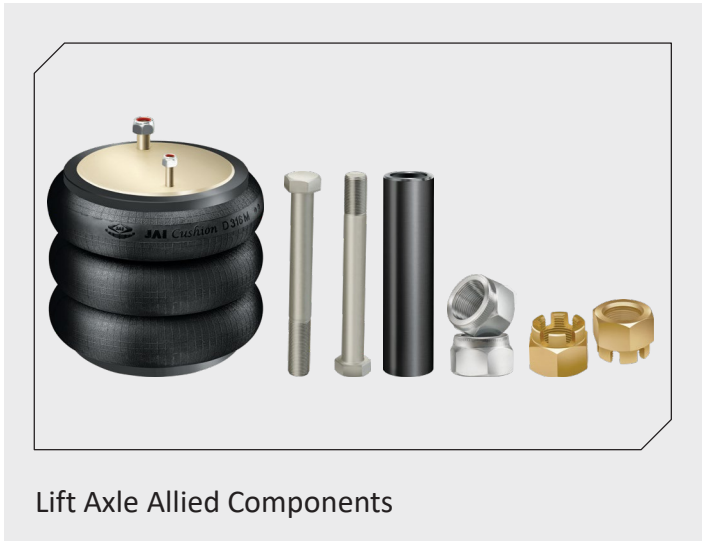

Lift Axle Allied Components

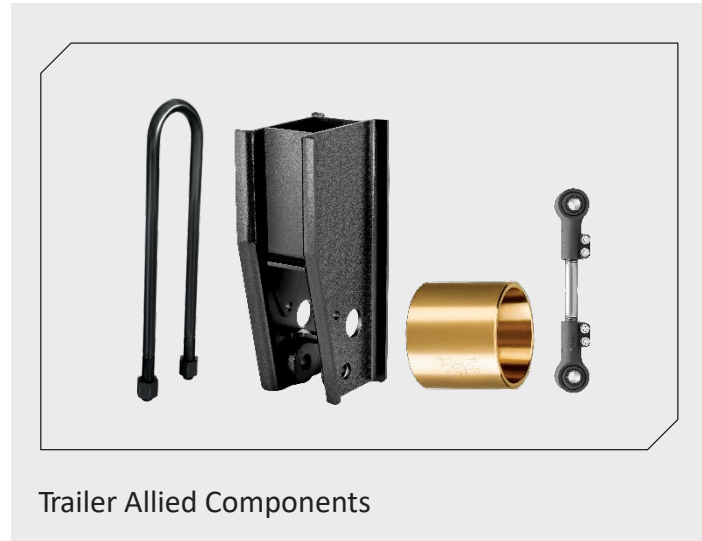

Trailer Allied Components

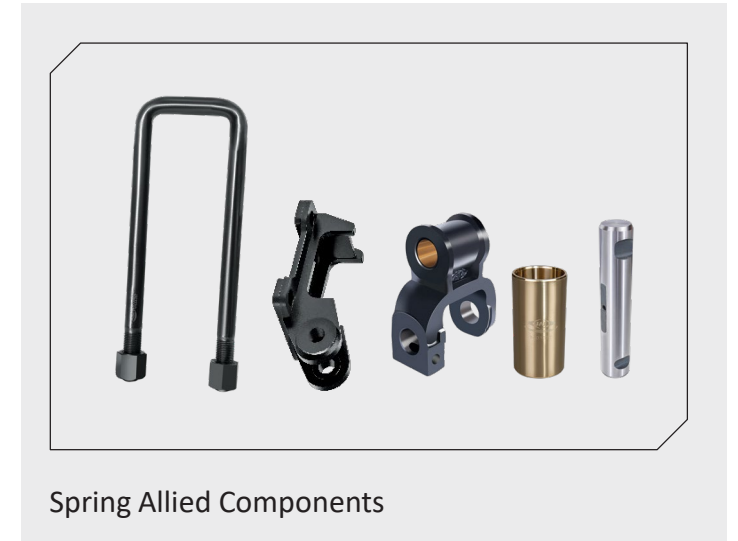

Spring Allied Components

# After Market India JAI's Product Portfolio



Brake lining

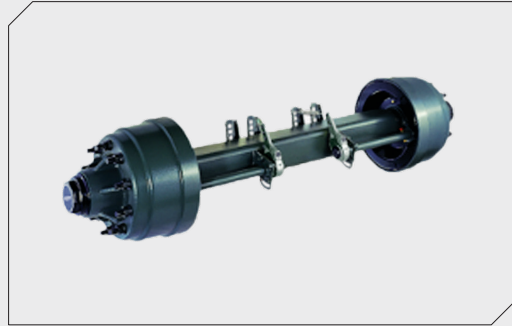

Trailer Axle

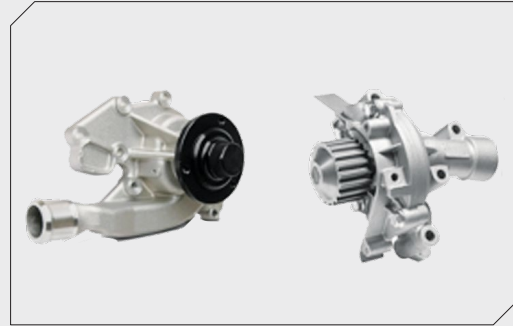

Water Pump



Jack Rod

**Most of the products above are only traded**

Jamna Auto Industries Limited ('JAI')



# Shareholding Pattern as on 31<sup>st</sup> December 2023

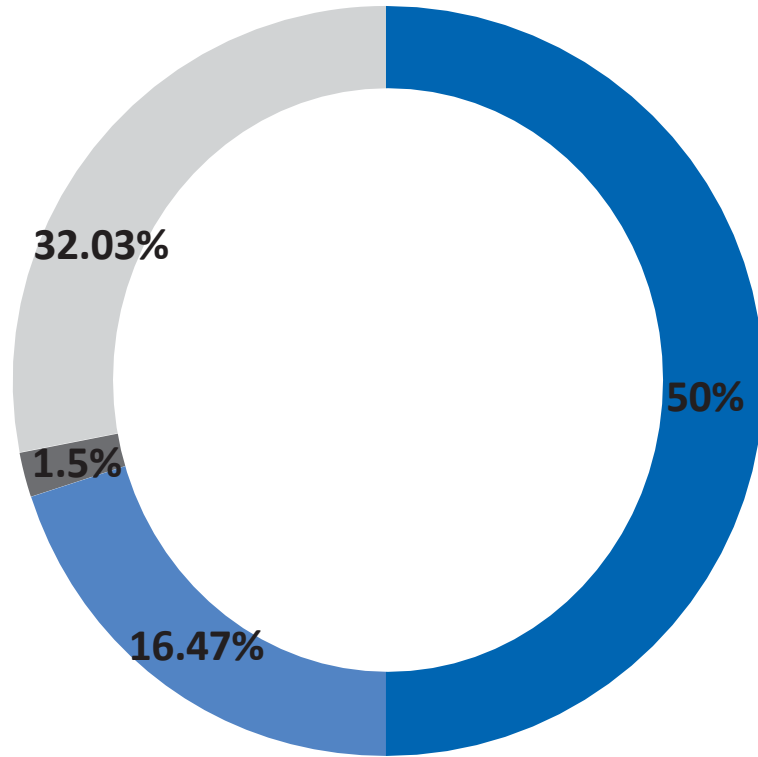

- Promoters
- Institutional investors

Categories	% Holding as on 31.12.2023	% Holding as on 30.9.2023
Promoters	50%	50%
Institutional Investors	16.47 %	18%
Bodies Corporate	1.5%	1.7%
Individual & Others	32.03%	30.3%
Total	100%	100%

# Contributing to the Society



We are committed to contribute to the social and economic welfare of communities in which we operate. Playing an active role in sustaining positive change within society, we aim to create opportunities for the holistic development of people from all sections of society.



Organize tree Plantation drives in YNR, Malanpur & Hosur.



Facilitates 84 meritorious students by gifting laptops, Mobiles & Cycles in YNR & Malanpur.



Distribute 1550 Blankets in Delhi, Gurugram, YNR and Pant Nagar.



Distribute 225 Nutrition kit to Anemic Girls & women in YNR & Chennai.



# Contributing to the Society



## Environment

- Developed Herbal park and constructed vermicompost pit in CHC Khizrabad-YNR and inaugurated by Shri Kunwarpal Singh Gujjar(Cabinet Minister-HR).
- Distributed 1745 jute bags to community people in YNR, Malanpur, & Hosur.
- Planted & distributed 865 saplings to community people allover locations. And installed 40 dustbins in Govt. schools of Malanpur and Jamshedpur.
- Produced 2000 kg vermin-compost in YNR & Jamshedpur.
- Organized a 3 cleanliness drives in Yamuna Nagar and involve community people and school students.



## Education

- Awarded 84 Govt. school's meritorious students by gifting laptop, smart phones & bicycles in YNR, Malanpur & Jamshedpur.
- Renovated stage in 3 Govt. School Ariyanwala, Kishanpura and Chachrauli including Steel shed and tiles work.
- Provide Annual Scholarship of GNK College and Institute students.
- Provided ceiling fans, Table, Chair, Floor Mat, almirah, Water Cooler, Shoes, Bags and Computer in YNR, Pant Nagar, Pillaipakkam and Chennai.
- Appointed 3 New Guest teachers in Govt. School Ariyanwala, Chikan and Chachrauli in YNR.
- Installed 25 iron Benches in Govt. College Chachrauli in YNR.
- 2000 dental kits were distributed to Govt. school students in YNR & JSR.
- Renovation of Govt. Middle School, Tajewala which includes Repairing of Roof, Semi Construction of Room and Construction of surrounded wall.



## Sports

- Provided Annual Scholarship to 51 sportspersons in GNK College in Yamuna Nagar.
- Provided monthly diet money to 06 sportspersons in GNK College in Yamuna Nagar.
- Sponsored a national level bodybuilder Mr. Shailesh Kumar & National level Archery Mr. Ashok Soren for next one year for his diet and training in JSR.
- Support for training to 4 sport person of Abhinav Bindra Foundation for one year Project.
- Provide Inverter and Water cooler to the DSO of Tezli stadium, Chachrauli.
- Developed & Inaugurated Open Gym in Panipat Prison by Hon'ble District & Session Judge Panipat Shri Sudesh Kumar Sharma.

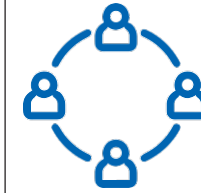

## Community Reach

- Distributed 1550 Blankets in Delhi, Gurgaon, Pant Nagar and YNR Region to hawkers, street stall holders, beggars, and those seeking shelter at Rain Baseras, Slums & Streets.
- Under the "Anemia Free India Campaign" organized blood testing camps through FPAI in Govt. schools and screened above 800 adolescent girls and find 150 Anemic Girls.
- Screened 350 people in 02 Eye Check-up Camps in adopted villages. Distributed required medicines & 150 spectacles to patients and conduct 19 Cataract operation successfully in YNR & Malanpur.
- We hosted an event in which we distributed nutrition kits to 150 Anemic girls students, and supplied nutrition kits to 46 anemic women. The esteemed Education & Forest Minister of Haryana Government, Shri Kunwarpal Singh Gujjar, graced the occasion as the chief guest.
- Distribute Aids and Appliances to 30 PwDs of 10 villages of YNR.
- Arranged lunch for 400 Migrant people in Yamuna Nagar under food For All Program on every month.
- Awarded certificates to 170 sewing trainees who have completed stitching & tailoring course in YNR.





**Thank You**

---