

Date: 04/12/2023

To,
Gen. Manager (DCS)
BSE Limited.
P J Towers, Dalal Street,
Fort, Mumbai-400001

SUB: INTIMATION OF BOARD MEETING UNDER REGULATION 29 OF SEBI (LISTING OBLIGATIONS AND DISCLOSURE REQUIREMENTS) REGULATIONS 2015.

REF: COMPANY CODE BSE: 531257

Dear Sir,

With regard to captioned subject, we would like to inform you that, the Meeting of Board of Directors of the Company is scheduled to **be held on 11th December, 2023**, to consider regarding following:

1. To consider regarding Related Party Transactions considered to be material.
2. To Fix Date, Time and Venue of Extra-Ordinary General Meeting/Postal Ballot Notice for taking shareholders' approval.
3. To transact any other business.

You are requested to take the same on record.

Thanking you.

Yours sincerely,

For, PRATIKSHA CHEMICALS LIMITED

MR. UPENDRA ADHVARYU
DIRECTOR
(DIN: 00483857)

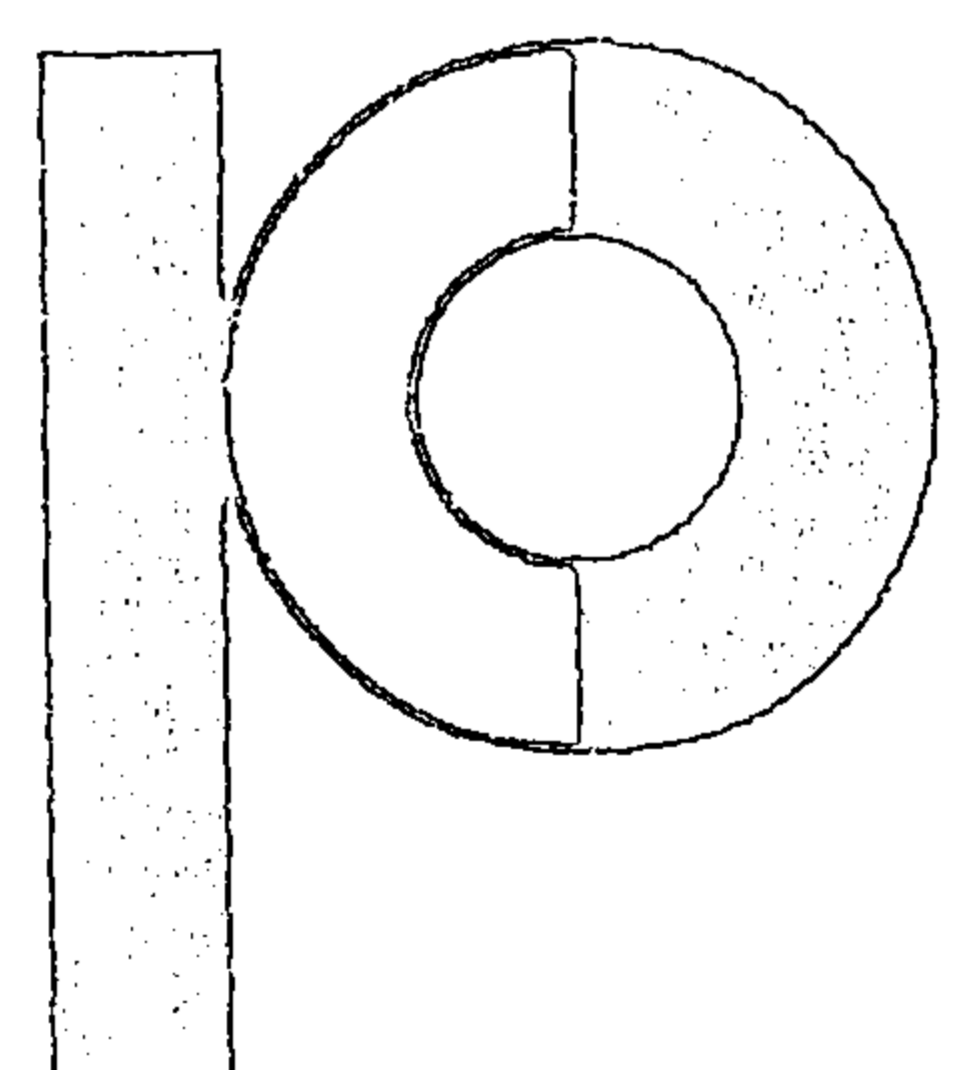

PRATIKSHA CHEMICALS LIMITED

Regd. Off : 3rd Floor, H. K. Complex , Nr. Dharnidhar Derasar, Paldi, Ahmedabad-380 007 India
Ph. 26632390, 26609530 Fax No : +91 79 26612843.

Website : <http://www.dharapratiksha.com> E-mail : exports@dharapratiksha.com

CIN : L24110GJ1991PLC015507

Factory : 195/2, Near Natraj Industrial Estate, Village Iyawa Vasna, Sanand.
(Dist : Ahmedabad) India. Phone 02717-284350