

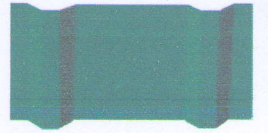

Structuring Dreams from Steel

Formerly Known as-
Bansal Roofing Products Private Limited
Bansal Roofing Private Limited



Bansal Roofing Products Ltd.

NSIC-CRISIL Rated Company, An ISO 9001-2015 Company

Registered Office : 3/2, Labdhi Industrial Estate, Acid Mill Compound, Ranmukteshwar Road, Pratapnagar, Vadodara-390 004, Gujarat-India.
(L) : 091-265-2580178, 2581082 (M) : +91 8511148598 Email : cs@bansalroofing.com
CIN No. L25206GJ2008PLC053761, Website : www.bansalroofing.com

Date: 01.12.2018

To,
General Manager,
Bombay Stock Exchange
BSE Limited
Phiroze Jeejeebhoy Towers,
Dalal Street, Mumbai – 400001

Sub: Investor Presentation – November, 2018
Scrip Code: 538546

Dear Sir/Madam,

Pursuant to the regulation 30 of Securities and Exchange Board of India (Listing Obligation and Disclosure Requirements) Regulations, 2015, we enclose here with updated Investor Presentation - November, 2018. The same is also available in our website (www.bansalroofing.com).

You may please to take the same in your record and suitably disseminated to all concerned.

Thanking You,

Yours Faithfully,

For Bansal Roofing Products Limited

Archi Shah

Company Secretary & Compliance Officer



Factory : Plot No.6, Raj Ind. Estate, Village: Vadadala, Jarod-Samlaya Road, Ta. Savli,
Dist. Vadodara, Gujarat, India. Pin 391 520. Telefax : +91-2667 251201



(An ISO 9001 : 2015
Certified Company)



Bansal Roofing Products Ltd.

Structuring dreams from Steel

Investor Presentation – November 2018

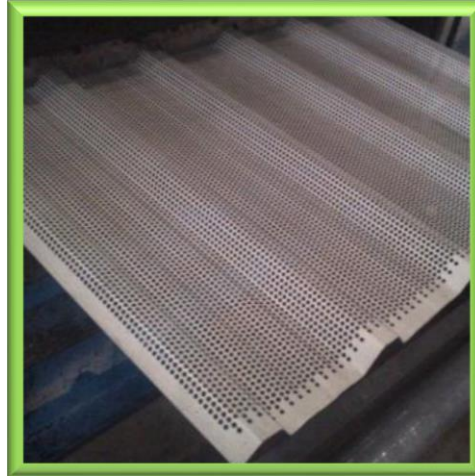
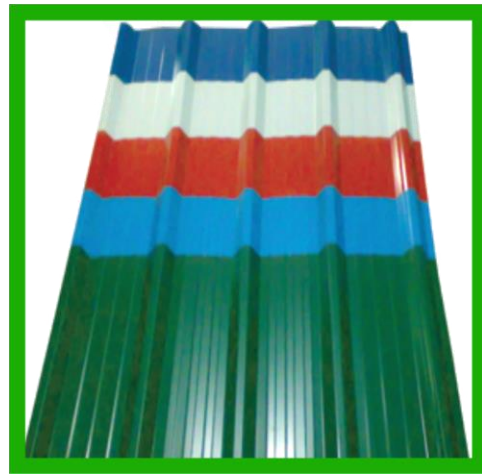

1	Executive Summary
2	Company Overview
3	Business Structure
4	Industry Overview
5	Financial Overview

Executive Summary



Executive Summary

Overview

- Bansal Roofing Products Ltd. (BRPL) was established by experienced technocrats having 23 years of experience in the field of Production, Marketing, and Project Management. It is listed on Bombay Stock Exchange (BSE), SME platform.
- The Company was incorporated in 2008, initially foraying into business of marketing of roofing sheets. It then moved into trading and later on into manufacturing of roofing & accessories.
- The company started their commercial production in the year 2012. Since then they have grown rapidly to become a one-stop solution provider for steel structures, ware houses, factory sheets and allied products.

Key Strengths

- One-stop solution for steel structures, shed and roof coverings
- Management Expertise with more than two decades of experience
- Necessary qualifications in place for tender business
- Strong Range of Products, Strong Brand Image
- Strong product basket - Foundation bolt to Roof top products from one place
- Extensive and Cost beneficial Manufacturing Facility
- Quality Assurance and Standards (ISO 9001:2008 certified Company)

Key Financial Highlights FY18 (INR) :



Product Basket

BRPL is a quality manufacturer of roofing products like:

- Pre-engineered building
- Color Coated Metal sheets (PPGI, PPGL, Bare galvalume, Aluminum) and its accessories
- FRP Plain & Profile sheets
- Polycarbonate sheets
- Perforated sheets
- Turbo ventilators
- "Z and C" purlin
- Metal Deck sheets

Company Overview



■ ■ ■ ■ ■ About Bansal Roofing Products Limited

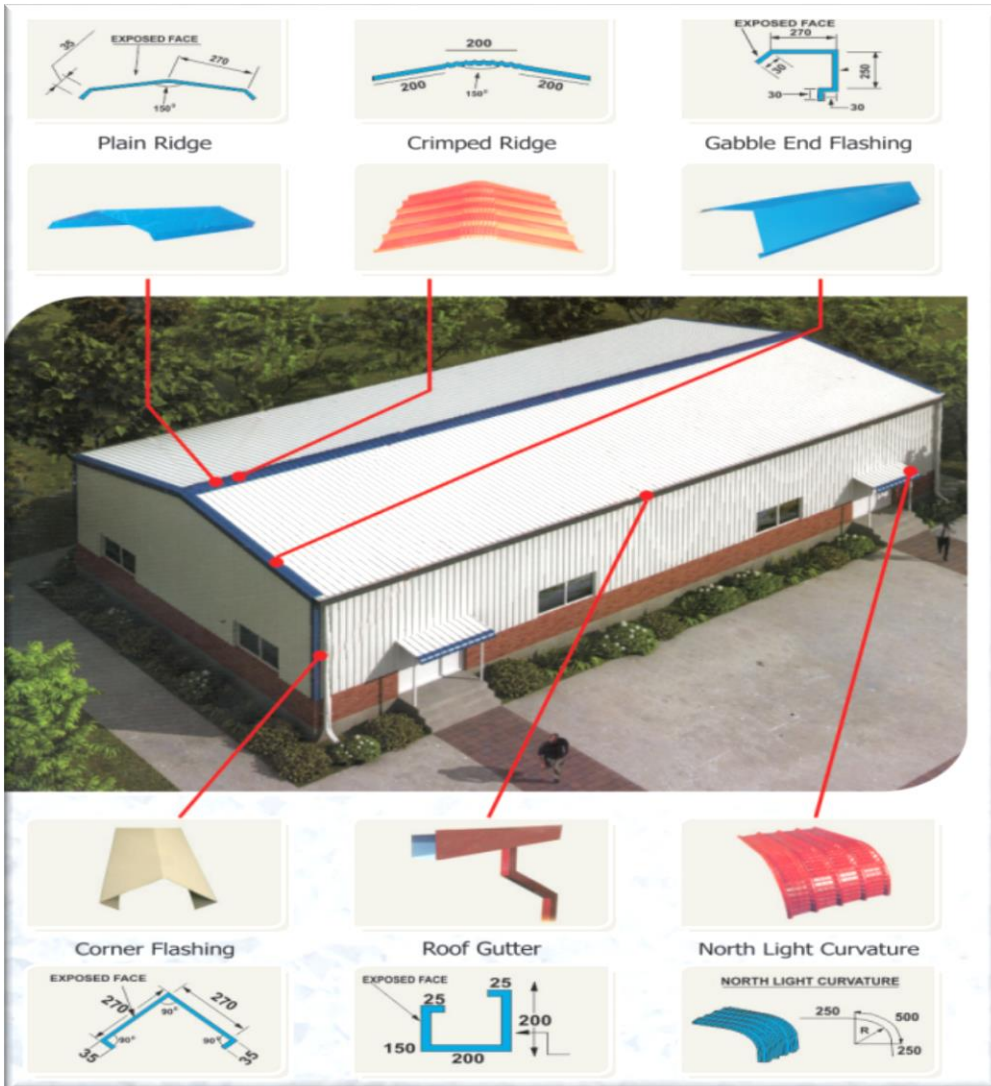

- Bansal Roofing Products Limited (BRPL) has started with roofing sheets and roofing accessories such as Colour Coated Roof Sheets, FRP Roof Sheets, Polycarbonate Sheets. It also manufactures Eco Ventilators and other miscellaneous Roofing Accessories and provide all roofing solutions to valuable customers under one roof. Key products manufactured by BRPL are Pre-engineered buildings, Metal Roofing sheets and allied products.
- Today it is a reputed Manufacturing Company for steel building i.e. Pre-engineering building.
- Company's manufacturing facility is situated near Vadodara, Gujarat. The products manufactured by the Company are made on automatic and semi-automatic Roll forming machine, Crimping Machine, Shearing Machine, folding machine, welding rectifier, chesar machine, radial drill machine, power press machine and many others.
- The company has an installed capacity to manufacture 1,410 tonnes on a monthly basis. The company is currently utilizing 41 per cent of its total installed capacity.
- BRPL is a CRISIL rated Company having "MSE 2" rating which means Highest Financial Strength and High Operating Performance. BRPL has been awarded with SKOCH ORDER OF – MERIT as INDIA'S BEST SMEs in March, 2015.
- BRPL is also ISO 9001:2008 certified company and was listed on BSE SME exchange dated 14th July, 2014.

Board of Directors



Kaushalkumar S Gupta - Director / Key Management Personnel

- Age 47 years, is the Chairman & Managing Director of the Company.
- Holds a Bachelor's Degree in Industrial Engineering from Saurashtra University.
- One of the founder promoters of the Company and Director since incorporation.
- Has more than 24 years of experience in various business activities ranging from Trading, Distribution, Manufacturing and Consulting.
- Main role in the Company is to strategize new business plans with industry trends and keeping consumer preference in mind.



Beena P Bisht - Ind. Non-Executive Director

- Age 41 years, holds a B.A. degree in Human Resource.
- Handles the investor grievance committee of the company and has 2 years experience with the company.



Shilpa A Jadeja - Ind. Non-Executive Director

- Age 45 years, holds a M.Sc. degree in Physics.
- Handles the remuneration committee and has 3 years experience with the company.



Sangeeta K Gupta - Director / Key Management Personnel

- Age 44 years, is also one of the founder promoters of the Company.
- Holds a Bachelor's degree in Arts (English Entire) from The Maharaja Sayajirao University of Baroda.
- Responsible for internal operations and staff support services of the Company.
- Originally appointed as Director of the Company on incorporation and was appointed as Whole-time Director of the Company on January 09, 2014.



Satishkumar S Gupta - Director / Key Management Personnel

- Age 56 years, is Director/Sales of the company .
- Holds a Diploma (Mechanical engineering).
- Experience of 20 years with ABB Limited as an executive engineer and 6 years with the company.



Bhavita D Gurjar - Ind. Non-Executive Director

- Age 30 years.
- Has completed her B.com, is in the audit committee of the company and has 3 years with the company.

Organization Structure

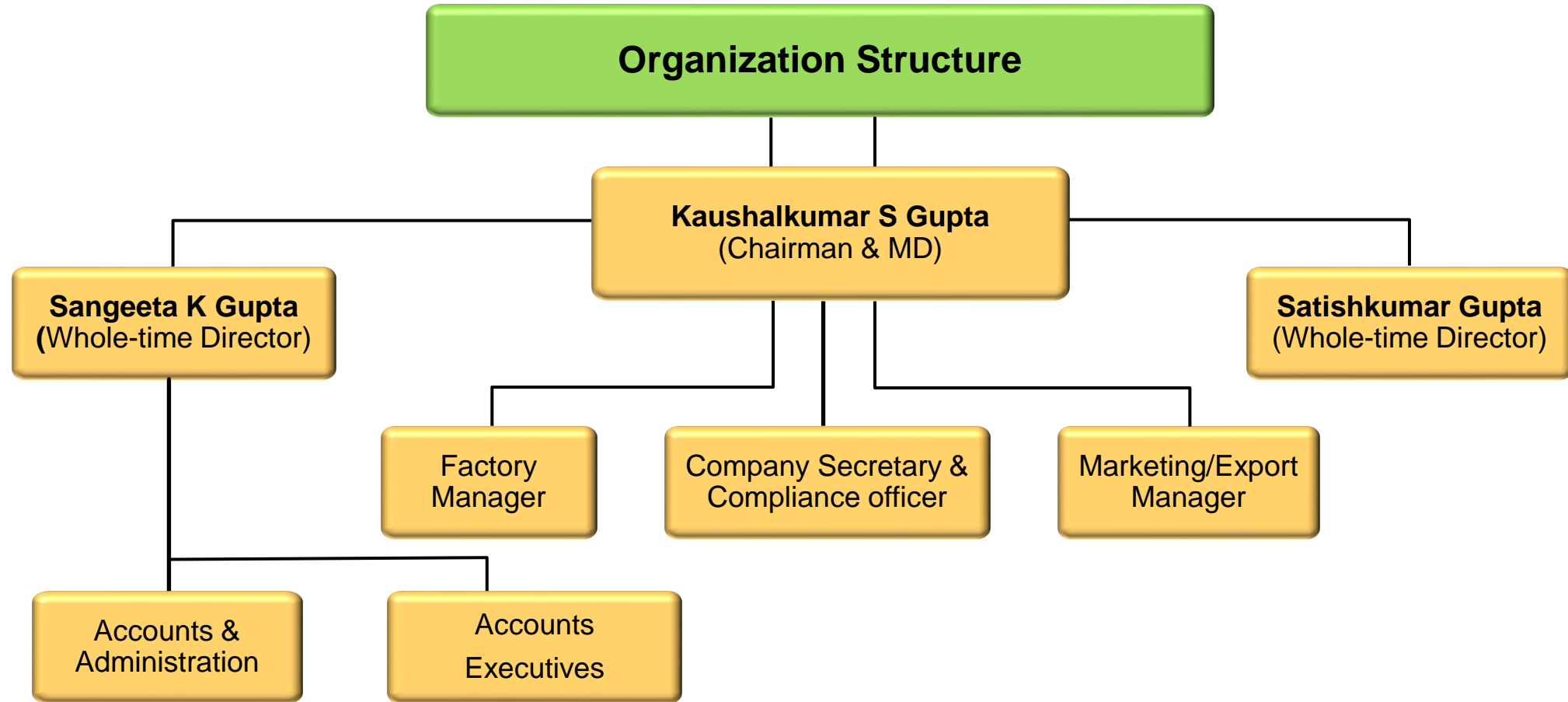

Milestones

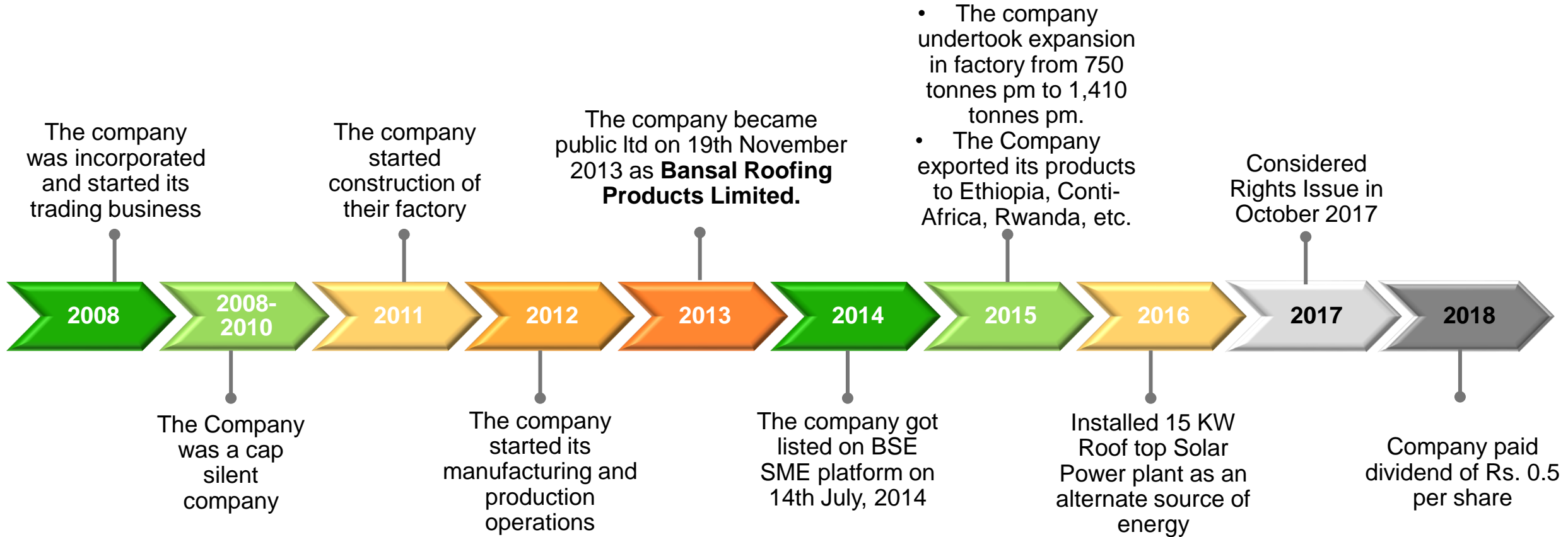

Marquee Clients



Our Facilities



State: Gujarat
District: Vadodara
Capacity: 1,410 tonnes pm.
Number of Employees: 66



Our Facilities



Shearing Machine



Roll Forming Machine



Z & C Machine



Crimping Machine



Mobile Crane



Gang Slitting Machine



Hydraulic Press Machine



De Coiler

Geographical Presence

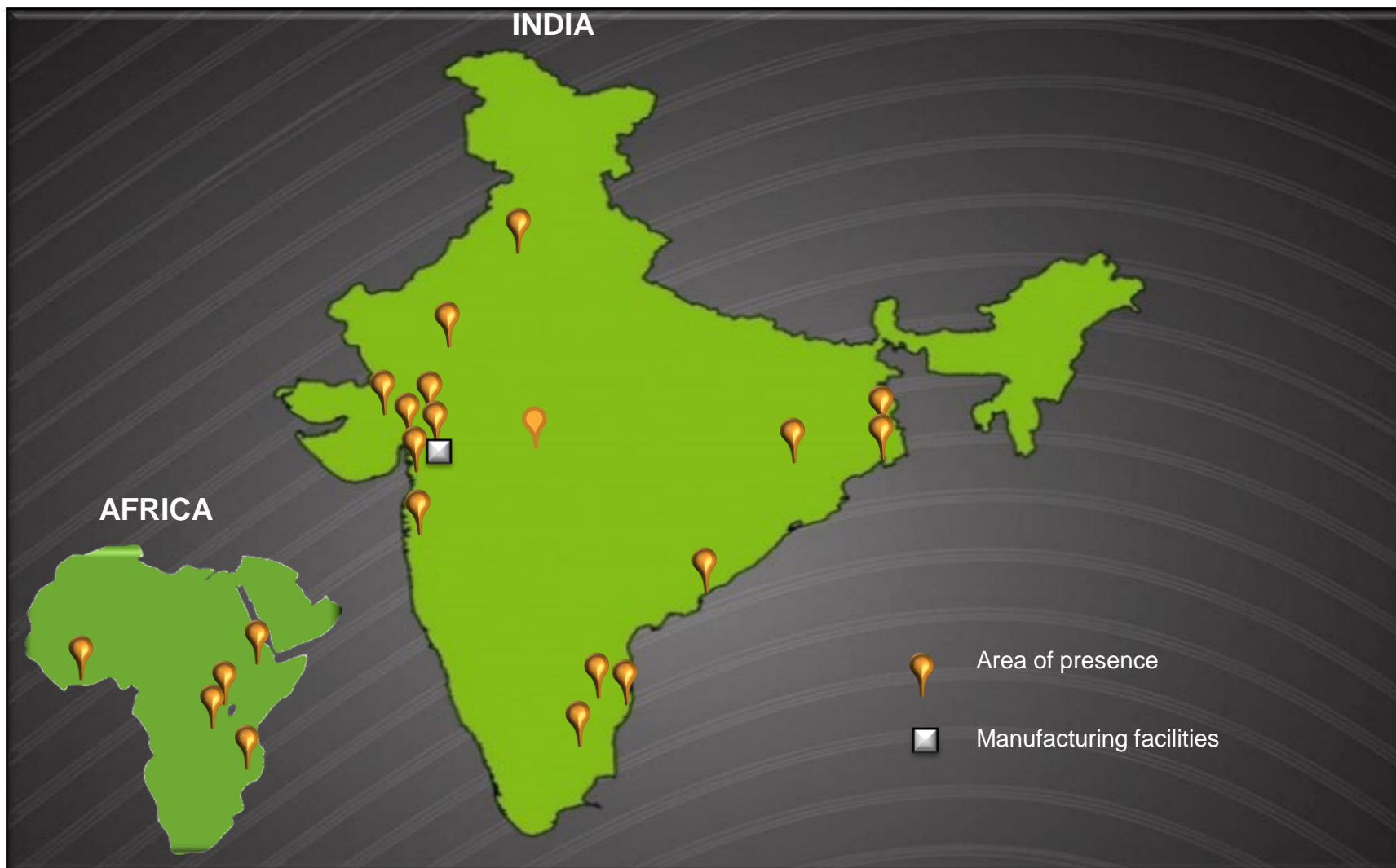

Region	State
Trichy Ranipet Vishakhapatnam	Telangana
Bhopal	Madhya Pradesh
Haldia Kolkata	West Bengal
Beawar	Rajasthan
Mumbai	Maharashtra
Nandesari Dahej Ahmedabad Mehsana Ekalbara Padra	Gujarat
Chennai	Tamil Nadu
Joda	Orissa
Hisar	Haryana

- East African Countries - Uganda, Ethiopia, Tanzania, Rwanda.
- West African Countries – Ghana, Ivory Coast

Key Strengths



Future Strategy



Future Strategy:

- Focus on high margin and high ROCE products
- Increased focus on Pre-Engineered Buildings
- Enhancing Capacity Utilisations
- Increasing Brand Value of the Company

Business Structure



Business Structure



Metal Roofing and accessories	Other Roofing Products	Pre-engineered structures	Services	Trading
Revenue Contribution: Current: 65% Proposed: 60%	Revenue Contribution: Current: 11% Proposed: 8%	Revenue Contribution: Current: 17% Proposed: 25%	Revenue Contribution: Current: 1% Proposed: 2%	Revenue Contribution: Current: 6% Proposed: 5%
Products: <ul style="list-style-type: none"> • Color coated Roofing sheets • North light curvature • Roof gutter • Crimped Ridge • Gabble End Flashing • Corner flashing • Plain Ridge • Other roofing Products • Miscellaneous Products 	Products: <ul style="list-style-type: none"> • Perforated metal Sheet • FRP roofing sheets • Polycarbonate Sheet • Metal Deck Sheet • "Z" And "C" Purlins • Eco ventilators 	Products: Pre-engineered structures	Services: Installation and Erection Services	Products: Trading of roofing related products
Capacity: 1,150 tonnes p.m. Capacity Utilization: 35% Gross Margins: 5-6%	Capacity: 35 tonnes p.m. Capacity Utilization: 45% Gross Margins: < 20%	Capacity: 200 tonnes p.m. Capacity Utilization: 45% Gross Margins: 15-25%	Gross Margins: 15-25%	Gross Margins: 3-10%

Note: Number as on H1-FY19

Our Products

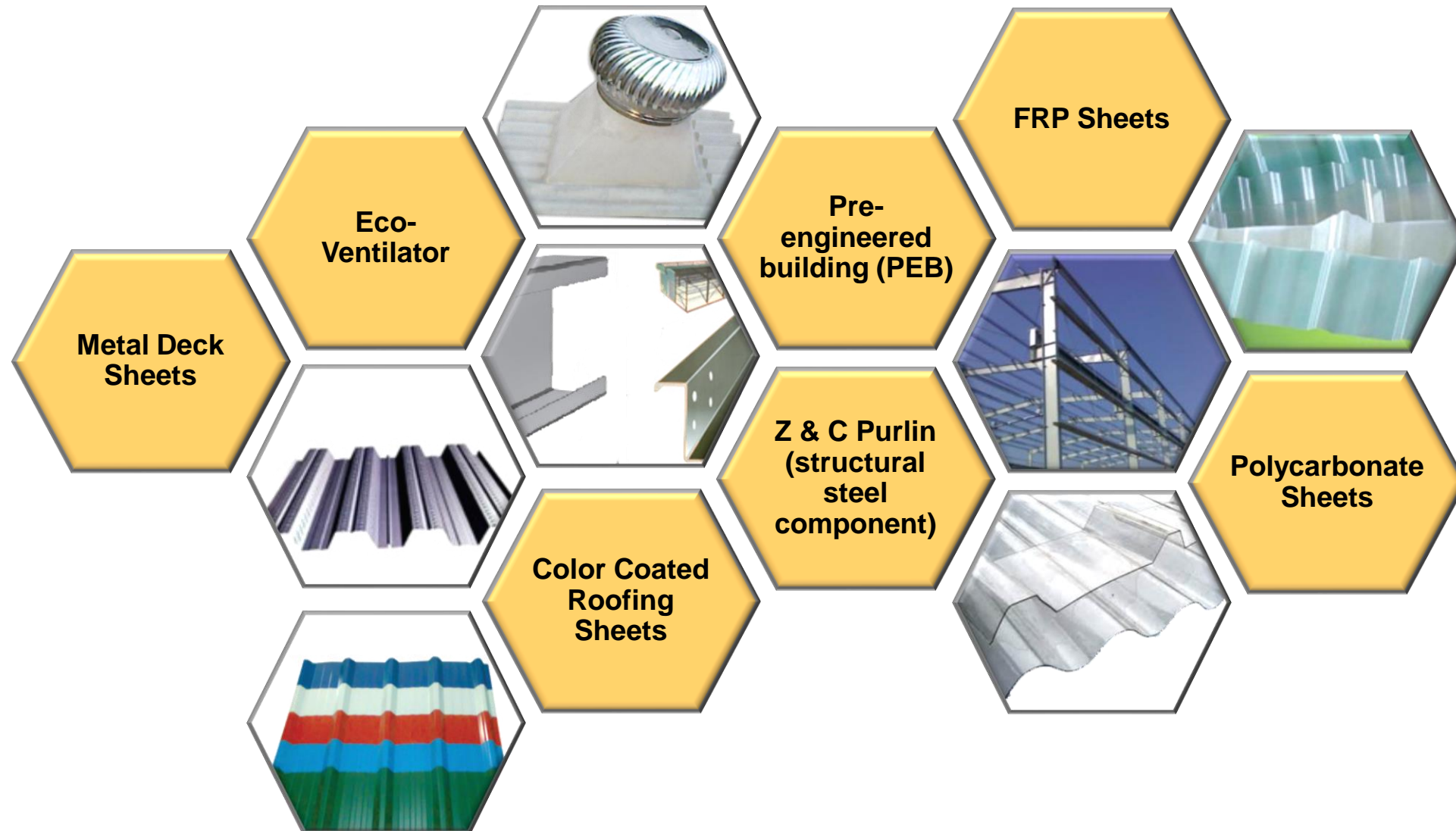

Roofing – Colour Coated Roofing Sheets

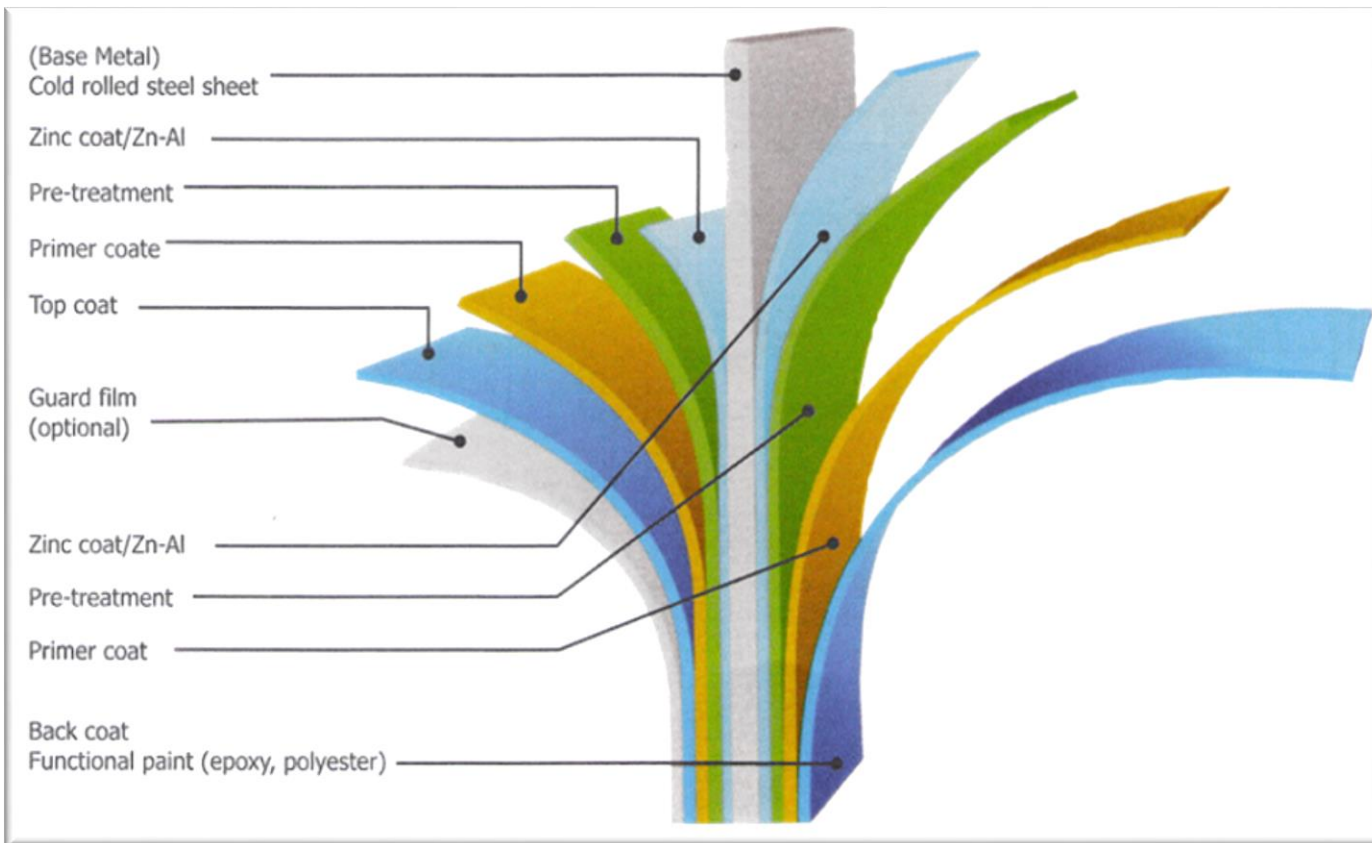

Bansal 1000 Profile [Hicover]

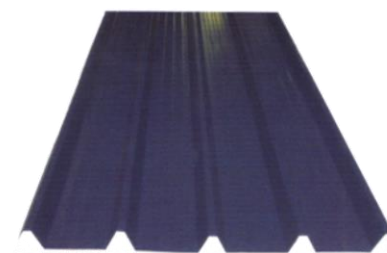

Bansal 980 Profile [Histrength]

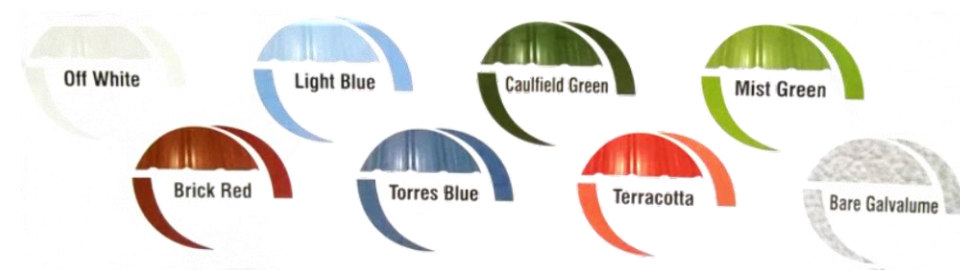
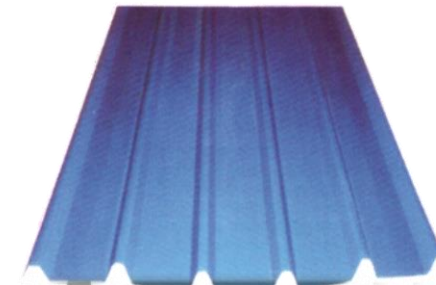

Applications :

1. Residential and Commercial buildings
2. Airport, Railways, Power houses
3. Shopping Malls
4. Barricading
5. Manufacturing Industries
6. Warehouses
7. Cold storages
8. Auditorium

Colour Coated Roofing Sheets are highly durable roofing sheets which have high quality colour coating throughout the roof or cladding. The thickness of coating depends on the weather conditions and its use. These roofing sheets come with lining enamel which is used as internal lining.

Accessories – Color Coated Roofing Accessories



North Light Curvature

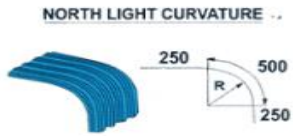

Roof Gutter

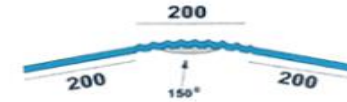
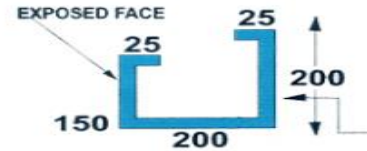

Crimped Ridge



Gable End Flashing



Plain Ridge



Corner Flashing

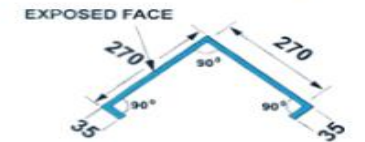

Other Roofing Products – Perforated Metal Sheet

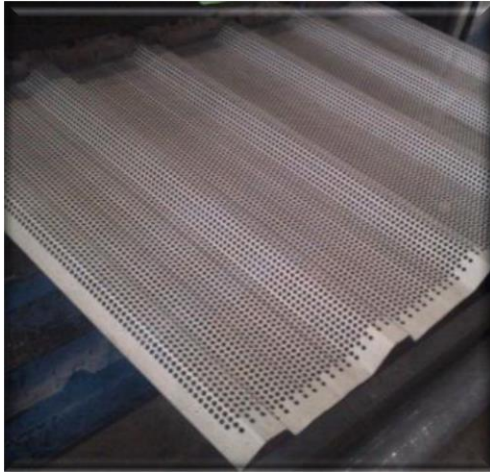

Perforated Metal Sheets are made through the metal stamping and manufacturing process. This is a sheet or plate with round holes punched in it or expanded metal.

Perforated materials are very versatile. From lightweight decorative elements to load-bearing structural components, perforated metal offers unique opportunities to combine strength, functionality and beauty. Perforated Sheet are also an excellent means of achieving sustainable design objectives.

Perforated sunshades and sunscreens provide privacy for building occupants without blocking the view. And they offer a comfortable level of natural lighting during daylight hours while deflecting heat to reduce the load on the HVAC system. Perforated canopies, facades and cladding can also be used to help control interior climate and save energy

Benefits :

Perforated materials have many advantages ranging from weight reduction through acoustic noise reduction to heat dissipation and much more.

- | | |
|--------------------------|---------------------|
| 1. Acoustic performance | 5. Heat dissipation |
| 2. Weight reduction | 6. Transparency |
| 3. Radiation containment | 7. Anti-Skid |
| 4. Separation | |

Applications :

- | | |
|----------------------|-----------------------------|
| 1. Interior Design | 8. Ceilings |
| 2. HVAC | 9. Furnishings |
| 3. Noise Control | 10. Stair Treads and Risers |
| 4. Security Ceilings | 11. Screening and Fencing |
| 5. Sunscreens | |
| 6. Building Facades | |
| 7. In-Fill Panels | |

Other Roofing Products – Polycarbonate & FRP Sheet



Polycarbonate Sheet

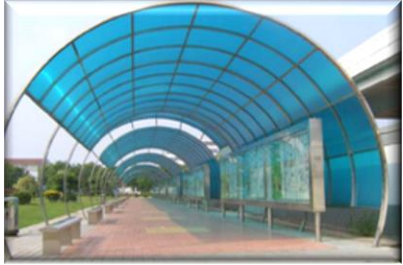

BRPL offers Polycarbonate sheets in a wide range of thicknesses and colours as well as in flat sheets, embossed, corrugated and multiwall.

- 1. Clear Compact:** These are light weight, strong flat sheets in different thicknesses. Transparency is like glass. It is very strong and available from 1.5 mm. to 20 mm. thickness.
- 2. Multiwall:** The product is light, strong, insulating and attractive. Being used widely for roofing, cladding and other applications. It is available in twin wall, triple wall, and multiple wall. It is cost effective and beautiful look wise.
- 3. Embossed:** These are plain sheets that come in a regular, prismatic embossing feature in different thicknesses ranging from 2 mm to 20 mm.
- 4. Corrugated:** Cement corrugation, Grecca, Sinus, Treford and any other profile. Grecca is available in translucent, transparent, opaque colours. Other sheets are available in natural transparent colours and are suitable for skylighting.

FRP Sheet

BRPL offers fiber glass Opaque and Translucent sheets for different applications. Product offered are U.V. Stabilized, Superior Impact Resistance . Better finish since it is made out of First Quality chopped glass mat and U.V. Polyester resin.

Product Range :

1. Translucent and Opaque –
 - a. Plain sheet with and without wrinkle.
 - b. Corrugated sheet in any Profile (GI, Pre-coated, PVC, Aluminium etc.)
 - c. Multi Coloured sheets
 - d. Textile Sheets
2. Translucent and Opaque - Domes and Pyramid
3. Any thickness between 0.8 mm to 10 mm.

Applications :

1. Translucent sheets provide natural daylight in Industrial and Domestic sheds. Light transmission is 40% to 90%.
2. Translucent sheets can be used as :
 - a. Side Cladding Sheets, instead of glass on main gate of house, shower partitions.
 - b. Decorative False Ceiling
 - c. Skylight area (OTS), Green House.
 - d. Canopy, Car Parking Sheds



Other Roofing Products – Metal Deck Sheet

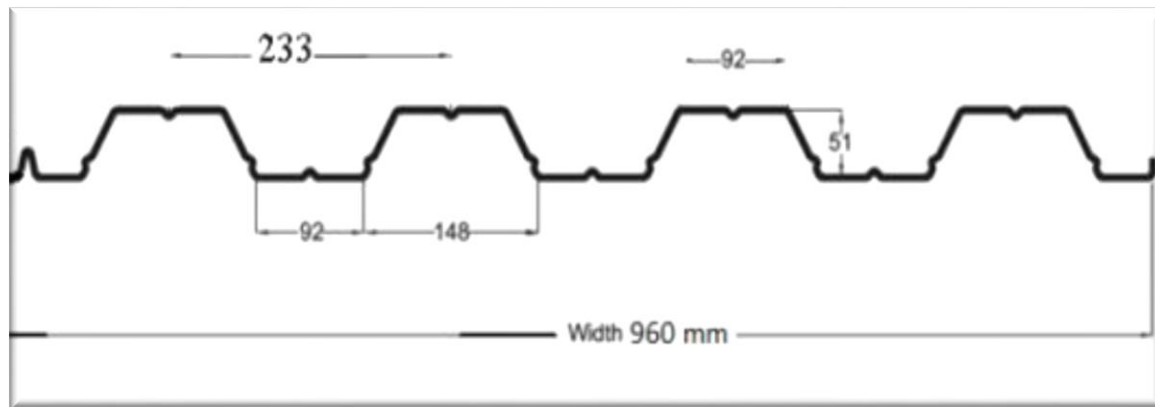
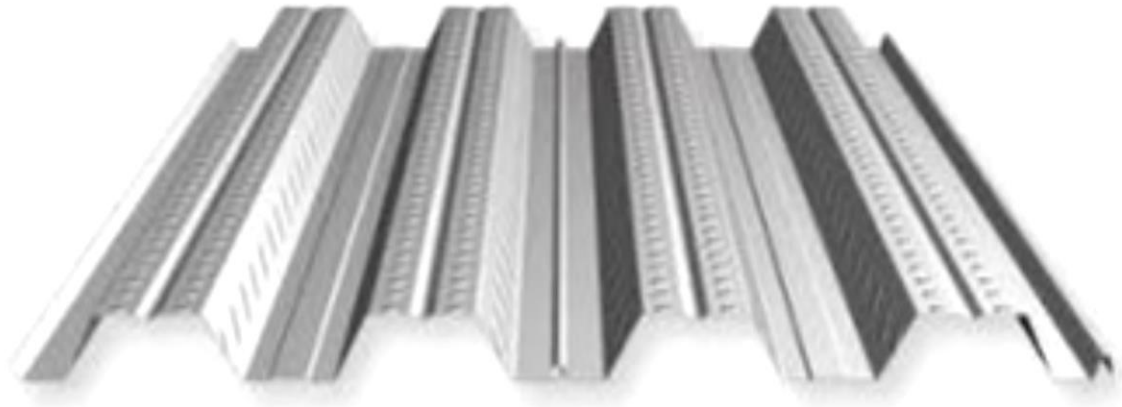

1. **Greater Durability:** The Bansal Deck Steel base has superior corrosion protection with guaranteed minimum yield strength depending on the specification used.
2. **Unbeatable strength:** When the steel and concrete composite slabs are constructed, they are lighter and stronger than most conventional slabs. Steel Decking provides flexible reinforcement, combined with compressive strength of concrete, for an all round stronger slab. The steel decking profiles are designed to inhibit any longitudinal slip between the steel and concrete in the slab itself, and any transverse movement between the slab and the supporting beams.
3. **Easy on-site handling:** Steel decking is transported to site in pre-cut lengths, and in pre-packaged bundles. These bundles can be easily craned into specific work areas, and the individual sheets can be quickly laid by hand.
4. **Speedy, safe construction:** One advantage of metal deck steel floorings is its speedy erection.

Other Roofing Products – ‘Z’ and ‘C’ Purlins

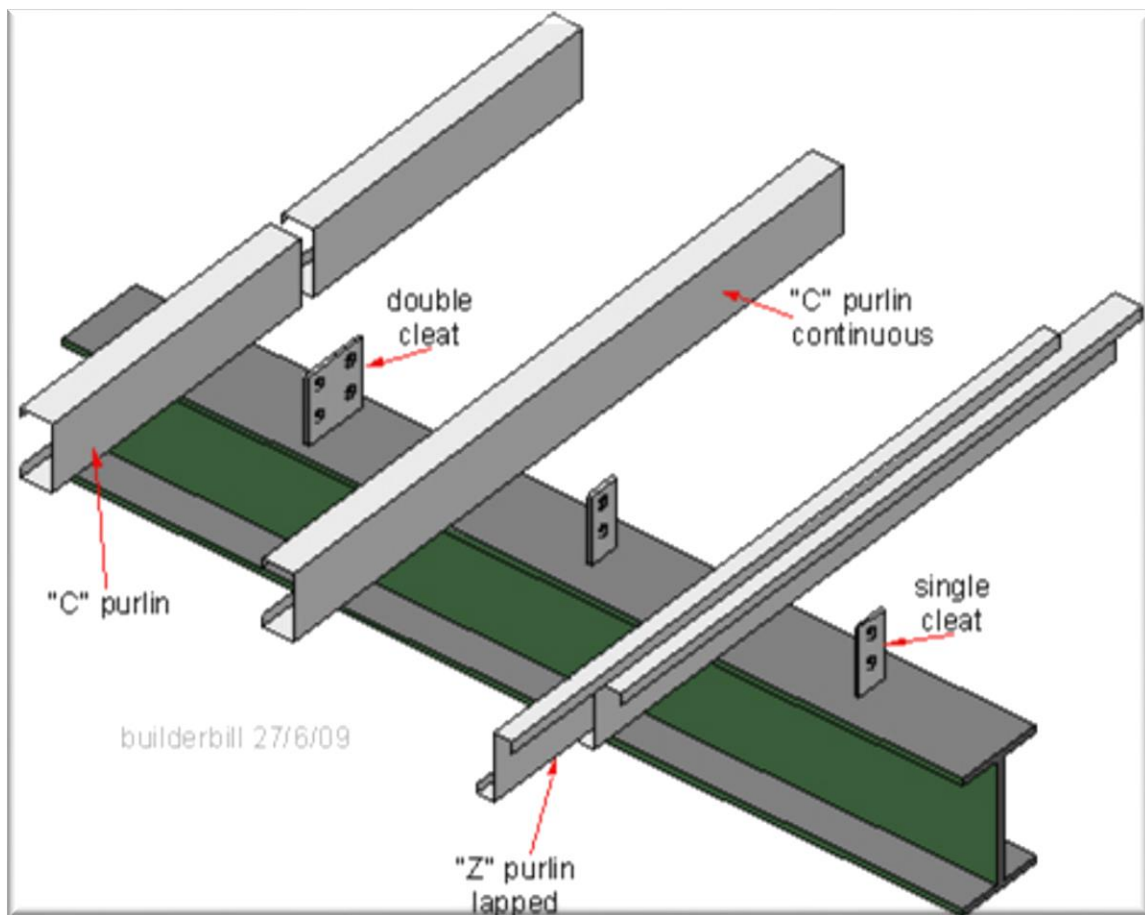

1. These purlins are most unique cold roll formed sections used to fix roof and side claddings.
2. The advantage of using these purlins are unlimited depth and thickness option that gives the designer the required freedom to design most economical purlin.
3. Minimum yield strength of these purlins will be 320 Mpa which enables designer to design light weight purlin.
4. ‘Z’ purlins can be supplied from 85 mm depth to 360 mm depth and thickness of 1.8 mm to 4 mm.
5. ‘C’ purlins can be supplied from 50 mm depth to 500 mm depth and thickness of 1.8mm to 4 mm.

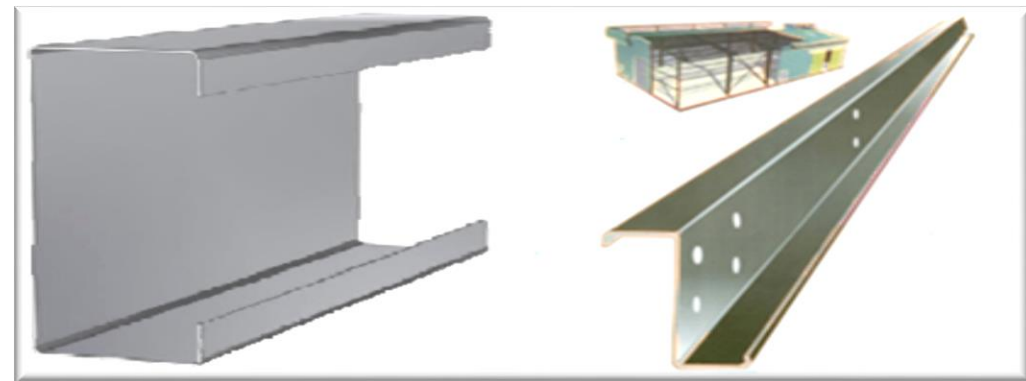

Other Roofing Products – Eco Ventilators



BRPL offers Turbo ventilator which is a self driven equipment installed on industrial roofs to extract inside air. Turbo ventilators are driven by wind hence no electricity or other power sources are required. As the ventilator is rotated by wind, the stale air inside is exhausted through its natural inward flow of fresh air is boosted.

The turbo ventilator operates by utilizing the velocity of the wind to induce air flow by centrifugal action. The centrifugal force caused by the spinning vanes creates a region of low pressure area which draws air out through the vanes. Air drawn out by the vanes is continuously replaced by fresh air from the outside. The slightest breeze will cause the turbine to spin and even after the breeze has stopped the flywheel effect of the rotor cage will use its stored energy to continuously remove air giving rise to ventilation. Suction is maintained even at low wind velocities.



Features

1. Rigid roll formed curved vanes in aluminium. optional S.S. 304 vanes are also available.
2. Roter shaft & nylon bush assembly concealed in mild steel casting.
3. Light weight & durable approximately 6.5 to 7 kgs audit.
4. Top plate & bottom ring is made of stainless steel.
5. Single piece U.V. stablised FRP base plate in different thickness. Option of opaque and translucent is available.
6. Virtually maintenance free, weatherproof and storm proof.

Pre-engineering Structures

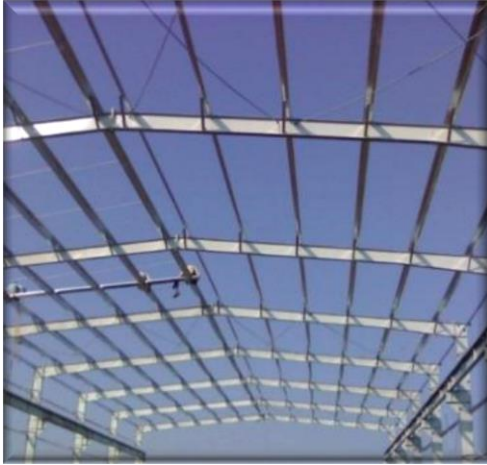

BRPL is all set to produce Pre-engineering buildings as per clients' requirements. The company has all the latest machineries to support this segment.

Pre-engineering building is a concept structure having high structural strength, economical designs while it supersedes the conventional fabrication, it lowers down the stress of foundation, hence there is less cost on civil construction as well.



Applications :

1. Factory
2. Warehouse
3. Workshop
4. Community hall
5. Commercial showrooms



Industry Overview



■ ■ ■ ■ The Indian Opportunity

Iron/ Steel & Steel Structures

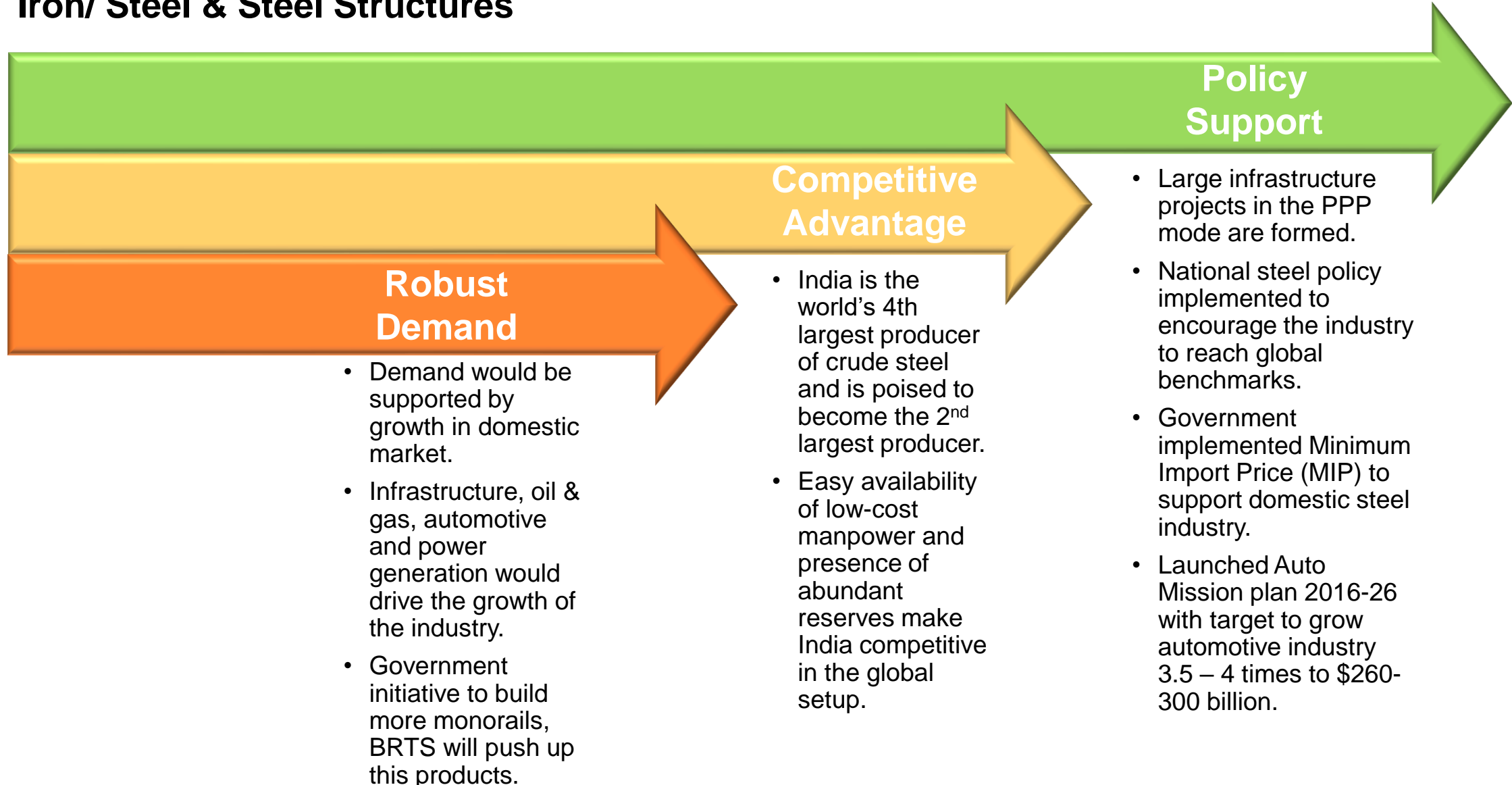

Industry Overview – Pre Engineering Structures

- PEBs are eco-friendly as its components are manufactured from cold formed sheet steel, as it is one of the world's most recycled material, therefore, depending on the manufacturing process, close to 95% of the components of a newly manufactured steel product can be recycled and also the end of any steel product's life, almost 100% of it can be recycled without losing its engineering properties, making PEB technology one of the greenest construction methods.
- PEBs use skylights and solar panels on rooftops to meet the daylight and captive power requirements. They help to reduce emissions and gain carbon credits unlike the conventional methods for powering the building.
- One of the emerging trends spurring the growth prospects for this market is the increasing demand for warehouses with a rise in the number of e-retailers, the demand for warehouses is also increasing. During 2015, online sales accounted for 7.5% of the total retail sales globally and will reach 13% by 2020.
- PEBs offer the fastest method to build warehouses compared to traditional methods, its demand among the end users will increase over the next few years.



PEB: A Boon for Building Industry

- The Indian Construction Industry has witnessed a growth trajectory quite comparable to the development of the overall economic infrastructure of the country. The Indian Pre-Engineered Steel Buildings (PEB) market is experiencing robust growth fueled by infrastructure development and the increasing popularity of PEB systems in the industrial sector.
- Looking into the time frame of tight project schedule, PEB structures can be used for tenders to deliver quality, esthetic, structural flexibility & ultimately promote usages of steel over concrete. The other advantage of the PEB structure is that steel can reduce carbon dioxide emission which will minimize pollution. PEB buildings are environment-friendly and energy efficient and are created with a high proportion of recycled content i.e. 70-80 per cent.
- Additionally, NAMO's focus on infrastructure with the development of railways, airports and roads will create huge business opportunities. The Government is also appraising and clearing the long held projects that will create the need for the PEB as it can help in completing these projects in a short period of time.
- PEB is a wave which is likely to become a trend soon in the Infrastructure division.
- The India pre-engineered buildings market is poised to grow at 11.63% CAGR and is estimated to reach USD 3.56 billion by 2020.

Source: Company, Transparency Market Research

Industry Overview – Roofing Products



The roofing industry is a dynamic industry, with new innovations, materials and tools cropping up on a regular basis. The growing domestic construction industry and the booming industrial sector are together seen as the major driving forces behind the increased demand for roofing products in India. Increased construction in urban areas and infrastructure development activities have kick-started the demand for modern, efficient roofing systems.

Market trends

- There is a wide spectrum of roofing materials, which are used for different structural, aesthetic, economic and performance reasons.
- Roof designs have developed from just being a weather performance element to an architectural trademark that can be environment friendly, structurally sound, reasonably priced and aesthetically attractive.
- Major shift is observed from clay tiles and conventional roofing system to metal roofing and cladding solution.
- Customers are looking for architectural solution which provides innovative shapes such as convex, concave in addition to new attractive colours.
- Demand of Colour coated metal sheet has gone up compared to conventional clay tiles and asbestos cement sheet which is health hazardous. Reason for increasing demand of metal sheet is its durability while being good looking because of numbers of colours available.

Growth Drivers

- Aesthetics, superior technology, durability, thermal efficiency are some of the significant driving factors which is in demand and Metal sheet with variety of options including Zinc coating, Zn-Al coated sheets, PVDF coating, PUF Insulation etc.
- Performance of Metal coated sheet with composite material will be in demand because of its unique quality and property.
- The total market size of steel roofing industry is approximately 1 Mn tonnes.
- The roofing market is estimated to reach a value of US\$124.50 Bn by the end of 2024, registering a healthy 6.40% CAGR from 2016 to 2024.

Financial Overview



Income Statement

PARTICULARS (INR Mn)	FY16	FY17	FY18	H1-FY19
Total Revenue*	225.3	272.9	327.3	252.4
Total Expenses	211.0	254.9	306.5	232.0
EBITDA	14.3	18.0	20.8	20.4
EBITDA Margins (%)	6.34%	6.60%	6.36%	8.08%
Depreciation	1.8	2.6	2.5	1.5
Finance Cost	2.1	3.0	2.5	0.5
Exceptional and Extraordinary Items	1.0	1.0	1.2	0.8
PBT	9.4	11.4	14.6	17.6
Tax	3.0	3.6	3.8	5.4
PAT	6.4	7.8	10.8	12.2
PAT Margins (%)	2.84%	2.86%	3.30%	4.83%
Diluted EPS (INR)	2.93	2.87	3.64	7.42

*Includes other Income

Balance Sheet

PARTICULARS (INR Mn)	FY16	FY17	FY18	H1-FY19	PARTICULARS (INR Mn)	FY16	FY17	FY18	H1-FY19
EQUITIES & LIABILITIES					ASSETS				
Shareholder Funds					Non-current Assets				
(A) Share Capital	22.0	22.0	33.0	33.0	(A) Fixed Assets				
(B) Reserves & Surplus	32.1	39.9	72.7	83.3	Tangible Assets	32.4	37.3	34.2	36.5
Non-current Liabilities					(B) Other Non Current Assets	3.1	2.1	2.6	1.8
(A) Long-term Borrowings	9.9	10.1	5.6	4.0					
(B) Deferred Tax Liabilities	1.3	2.2	2.4	2.5	Current Assets				
Current Liabilities					(A) Inventories	32.7	47.6	75.0	69.5
(A) Short term Borrowings	25.2	11.7	23.3	3.4	(B) Trade Receivables	14.0	11.7	13.8	14.3
(B) Trade Payables	4.7	14.3	15.0	9.8	(C) Cash & Cash Equivalents	4.2	2.4	26.7	9.7
(C) Other Current Liabilities	4.3	5.5	6.3	5.8	(D) Short-term loans & advances	4.3	3.3	7.2	11.3
(D) Short-term provisions	0.9	1.3	2.1	6.0	(E) Other Current Assets*	9.7	2.6	0.9	4.7
GRAND TOTAL - EQUITIES & LIABILITIES	100.4	107.0	160.4	147.8	GRAND TOTAL – ASSETS	100.4	107.0	160.4	147.8

* Other current assets include deposits

Financial Highlights



Total Revenue (INR Mn)

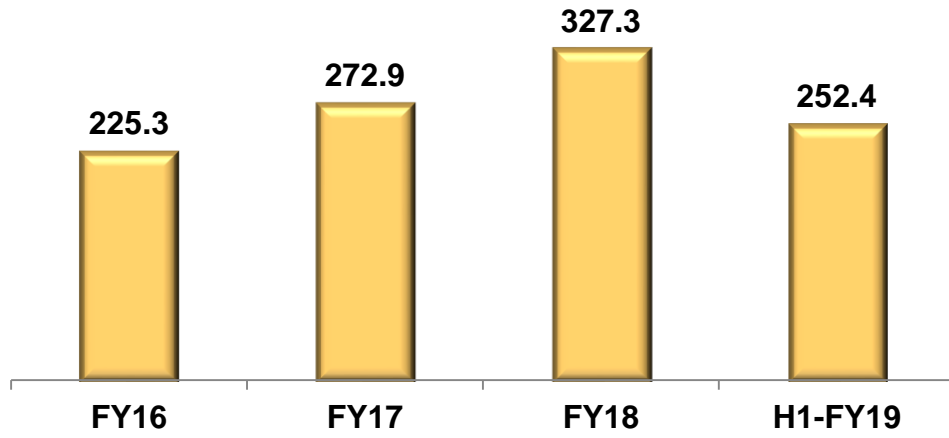

EBITDA (INR Mn) EBITDA Margins (%)

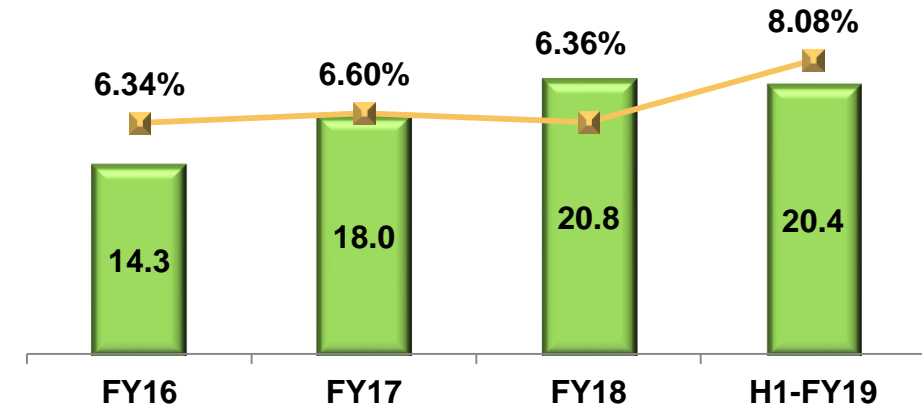

PAT (INR Mn) PAT Margins (%)

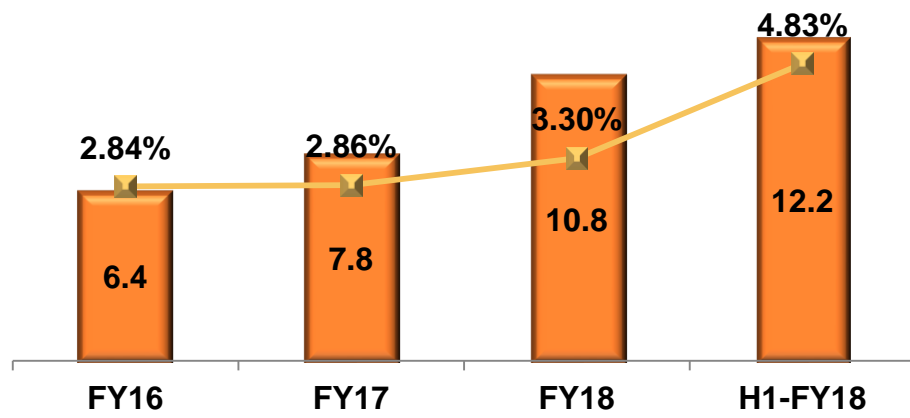

Networth (INR Mn)

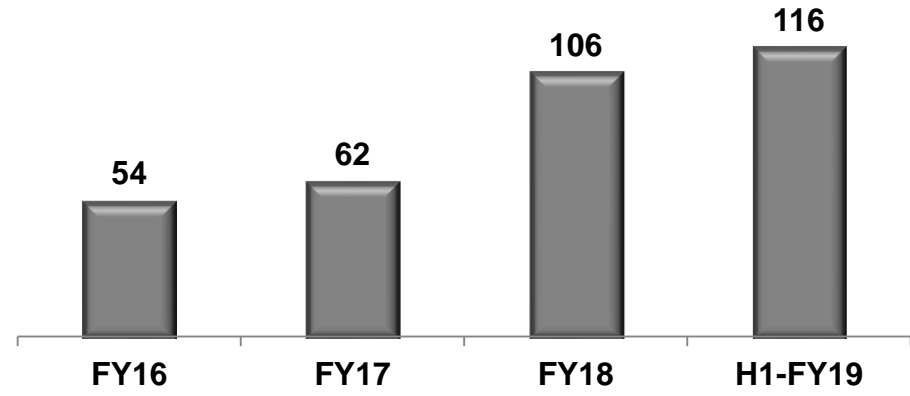

DISCLAIMER



No representation or warranty, express or implied, is made as to, and no reliance should be placed on, the fairness, accuracy, completeness or correctness of the information or opinions contained in this presentation. Such information and opinions are in all events not current after the date of this presentation. Certain statements made in this presentation may not be based on historical information or facts and may be "forward looking statements" based on the currently held beliefs and assumptions of the management Bansal Roofing Products Limited ("Company" or "BRPL" or "Bansal Roofing Products Ltd."), which are expressed in good faith and in their opinion reasonable, including those relating to the Company's general business plans and strategy, its future financial condition and growth prospects and future developments in its industry and its competitive and regulatory environment.

Forward-looking statements involve known and unknown risks, uncertainties and other factors, which may cause the actual results, financial condition, performance or achievements of the Company or industry results to differ materially from the results, financial condition, performance or achievements expressed or implied by such forward-looking statements, including future changes or developments in the Company's business, its competitive environment and political, economic, legal and social conditions. Further, past performance is not necessarily indicative of future results. Given these risks, uncertainties and other factors, viewers of this presentation are cautioned not to place undue reliance on these forward-looking statements. The Company disclaims any obligation to update these forward-looking statements to reflect future events or developments.

This presentation is for general information purposes only, without regard to any specific objectives, financial situations or informational needs of any particular person. This presentation does not constitute an offer or invitation to purchase or subscribe for any securities in any jurisdiction, including the United States. No part of it should form the basis of or be relied upon in connection with any investment decision or any contract or commitment to purchase or subscribe for any securities. None of our securities may be offered or sold in the United States, without registration under the U.S. Securities Act of 1933, as amended, or pursuant to an exemption from registration there from.

This presentation is confidential and may not be copied or disseminated, in whole or in part, and in any manner.

Valorem Advisors Disclaimer:

Valorem Advisors is an Independent Investor Relations Management Service company. This Presentation has been prepared by Valorem Advisors based on information and data which the Company considers reliable, but Valorem Advisors and the Company makes no representation or warranty, express or implied, whatsoever, and no reliance shall be placed on, the truth, accuracy, completeness, fairness and reasonableness of the contents of this Presentation. This Presentation may not be all inclusive and may not contain all of the information that you may consider material. Any liability in respect of the contents of, or any omission from, this Presentation is expressly excluded. Valorem Advisors also hereby certifies that the directors or employees of Valorem Advisors do not own any stock in personal or company capacity of the Company under review.



For further information please contact our Investor Relations Representatives:

Mr. Anuj Sonpal

Valorem Advisors

Tel: +91-22-4903-9500

Email: bansal@valoremadvisors.com

Thank You

