

GO DEEPER

Transform business with IT

Investor Presentation
Q1 FY 17



Product Engineering
Enterprise IT Services
Technology Infrastructure

DEPTH MAKES A DIFFERENCE

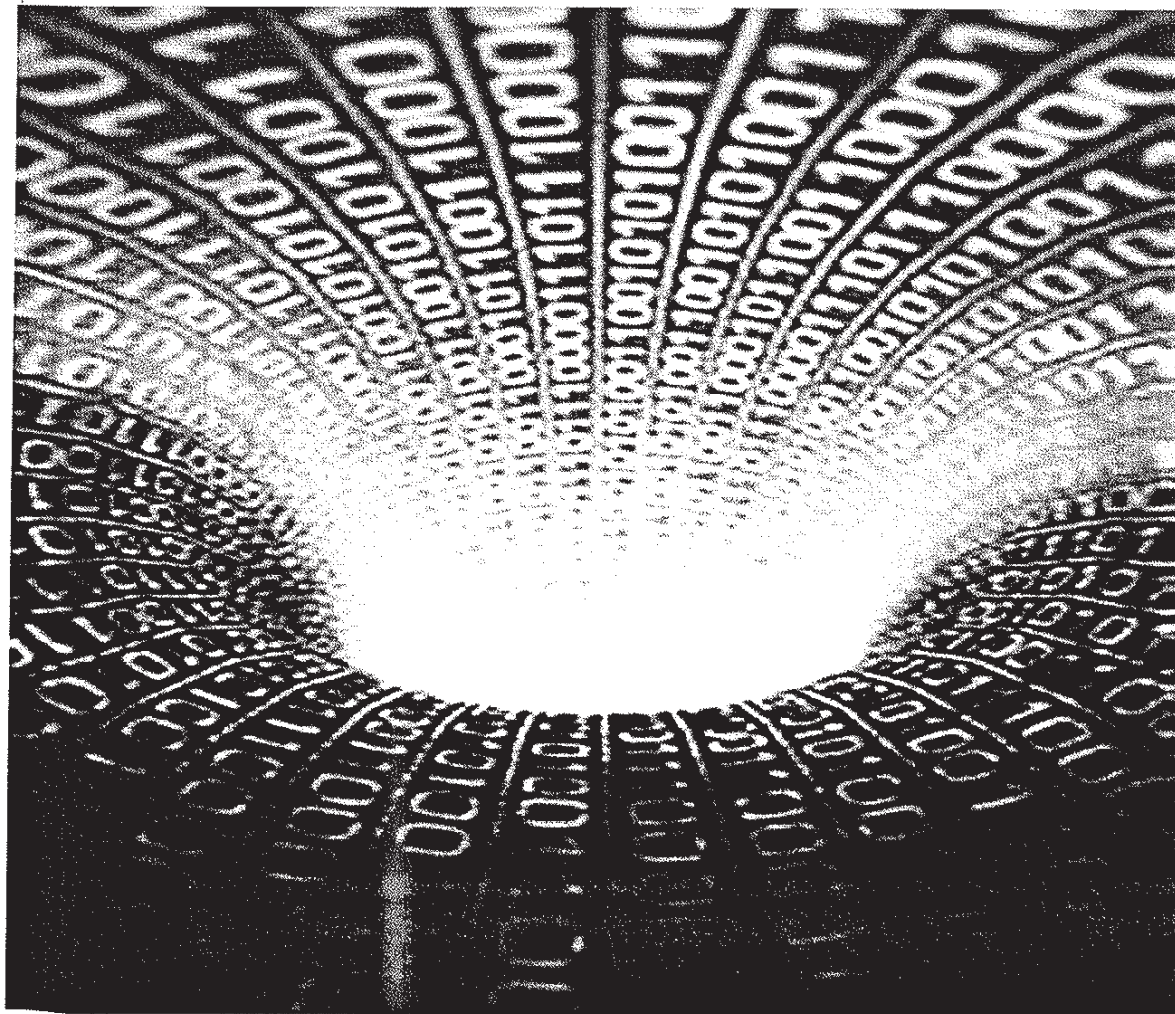

For the Customers

IT Partner of choice for transformation thru deeper industry, technology & customer focus

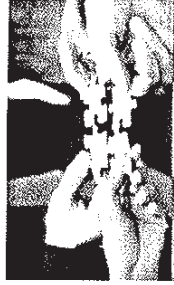

For the Employee

A fun & fearless environment where the potential & passion for work flourishes



For the Community

CSR initiatives to support IT needs of projects with Social impact



A world class firm
that is a benchmark for
Catalyzing Business
Transformation for our Clients,
Fulfilling Employee Aspirations &
Caring for our wider Community

through Depth of:
Thought Leadership
Customer Centricity
Execution Excellence

Sonata Software Limited

Reporting Segment	Legal Entities	Geography	Nature of Business
International IT Services	Sonata Software Ltd	India	<ul style="list-style-type: none"> Digital IT solutions & services Product Engineering Services IT Consulting & Outsourcing Managed IT Services
	Sonata Europe Ltd	UK	<ul style="list-style-type: none"> Software Service & Development
	Sonata Software GmbH	Germany	<ul style="list-style-type: none"> IT Program Mgmt. for Travel customers
	Sonata FZ LLC	Dubai	<ul style="list-style-type: none"> Sales & Marketing Account Management IT Program Management
	Sonata Software North America	USA	<ul style="list-style-type: none"> Onsite IT Services Account Management IT Program Management Sales & Marketing
	Sonata Software Qatar	Qatar	<ul style="list-style-type: none"> Onsite IT Services Account Management IT Program Management Sales & Marketing
	Rezopia Inc	USA	<ul style="list-style-type: none"> Cloud based PaaS travel IT solutions platforms
	Halosys	USA	<ul style="list-style-type: none"> Unified Enterprise Mobile Enablement platform
	IBIS Inc	USA	<ul style="list-style-type: none"> Supply Chain solutions for Distributors, Manufacturers & Retailers
	Domestic Products & Services	Sonata Information Technology Ltd	India



International Services

- Product Engineering & Enterprise IT solutions
- International footprint
- 29% of Co Revenues
- 76% of Co PAT



Technology Infrastructure

- IT Infrastructure Consulting, Licensing & Deployment
- Primary India footprint
- 71% of Co Revenues
- 24% of Co PAT



International IT Services

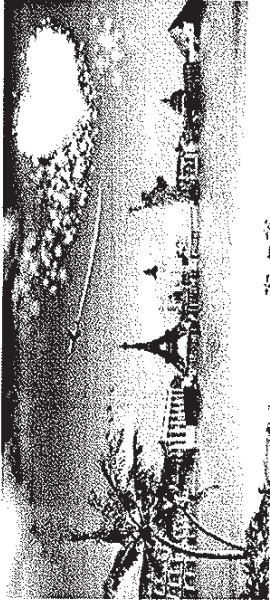

Travel

hybris software
AN SAP COMPANY
Most Innovative Partner
2012

rezo pia
SONATA SOFTWARE

TO | OTA | Corporate | Air | Rail

Strategic Customers

- World leading Tour Operator
- Top NA Corporate Travel Co

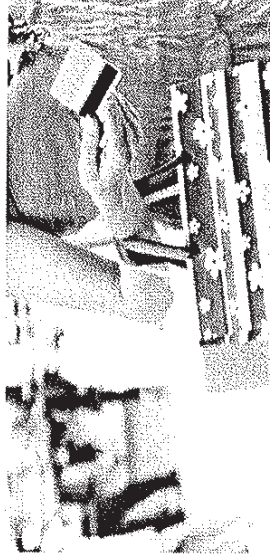

Retail & Distribution

Advanced Supply Chain Software



Microsoft
Dynamics

hybris software
AN SAP COMPANY
Most Innovative Partner
2012

Hyper | Grocer | Apparel | CPG | Industrial

Strategic Customers

- World leading Retailer
- Global F&B CPG Leader



ISV

Windows Azure

Java

ERP | SCM | Travel | Retail

Strategic Customers

- Global Software Leader
- Top SMB ERP Co

**DIGITAL
ENGAGEMENT**

- Omni-channel Commerce
- Analytics & Personalization
- CRM, Loyalty
- Mobile & Social Business

*Winning the Shift to Digital
Commerce
Top travel company*

**ENTERPRISE
EFFICIENCY**

- ERP
- SCM, HR & Finance
- BI & Analytics
- Mobile & Social Work

*Direct Store Distribution
Solutions
Global CPG leader*

**IT COST
MANAGEMENT**

- Managed Services & Infrastructure
- Cloud & Virtualization
- Licensing

*Remote Infrastructure
Management
Top European Retailer*



hybris software
AN SAP COMPANY



Microsoft
Dynamics



appcelerator



**PRODUCT
INNOVATION**

- Cloud engineering
- Mobile engineering
- Analytics integration



*Cloud & Mobile Enabled SaaS
Migration
Global SMB ERP ISV*

**PRODUCT
ENGINEERING**

- Consult, Architect
- Develop, QA
- Performance Engineering
- Globalize and Localization



*End-to-end engineering
services for an ERP
World leading ISV*

**PROFESSIONAL
SERVICES**

- Professional Services
- Integration, Customization
- Sustenance Engineering
- Product support



*Premium managed product
support
Leading cloud platform*

Enabling a World Leader in Travel Retail
stay ahead of the digital business shift

Evolution from brick and click to Omni-
Channel business

- 20%+ YoY digital sales growth, 50%+ digital revenue

Front Office to Back Office IT systems services

- 300+ team of On-site and Off-shore mix;
30% saving in IT costs, est > 50Mn E p.a.;
50+ core applications transitioned,
modernized; >80% Managed Services

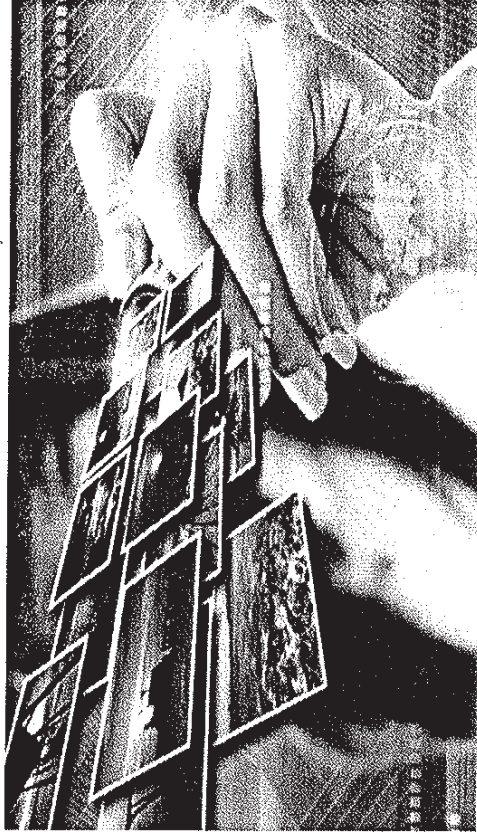

10 Year Partnership Milestone

"Sonata is a very important extension of the team and over the years has made a significant contribution to our success in serving our customers better than anyone else in our business sector." Director IT

Partnering launch of a new ERP by a Global Software leader

Engineering Excellence

- Beta One thru to global roll-out stages with ERP & engineering skills
- Vertical solutions partner – industry specific offering of core ERP

Value Added Services

- Engineering and integration services to partner eco-system globally
- Managed support with SLA adherence improved by over 30% to > 90%
- Go-to-Market partner with marquee Fortune 500 clients wins and project implementations



10 Year Partnership Milestone

*“Sonata has been an **important partner** in our ... journey for over a decade. The expertise they bring to the table makes **them a valuable part of the ecosystem**., its partners and customers who seek to get more out of our enterprise class business solution. This 10 year anniversary is a significant milestone in our relationship with Sonata and we look to newer horizons ahead.” VP Engineering*

<p>Consumer</p> <p>IT Connected world - Seamless, Personalized, Social Commerce</p>	<p>Customer</p> <p>Transform business to digital in order to use new technologies</p>
<p>Solutions that keep your business ready for a digital future</p> <ul style="list-style-type: none"> Travel : the future of Travel Experience Retail & Distribution : grow with Brick & Click ISV : future ready software 	
<p>Sonata</p> <p>Digital Engagement: Integrated Omni-Comm. + Mobility + Analytics + Cloud based solutions</p> <p>Industry specific IP led platforms + services</p>	

Turnkey partner for mid size (USD 500M+) customers in Travel, Retail & Distribution, ISV vertical

Next Gen Travel Experience



Omni Channel Retailer



Digital Distribution

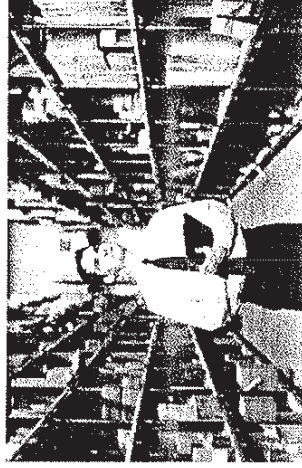

Rezopia Travel Experience Platform

- Search & Book across Web, Mobile, Shop & Call Centre channels
- On the fly packaging across Air, Rail, Hotel & ancillary service inventory
- Pre-Built Mobile & Analytics features
- Integration to leading GDS and ERP applications

Brick & Click Retailing Platform

- Seamless Personalized Shopping Experience – In Store, Mobile, Online
- Pre-built Customer and Store mobile service Apps
- Pre-built big data Analytics platform
- Integrated to core Retail ERP

Modern Distribution Platform

- Advanced Supply Chain Software – built-in functionalities like sales & operations planning, demand planning, revenue management.
- B2B Ecommerce
- Mobile Ordering & Fulfillment Apps
- Core ERP enabled on Microsoft Dynamics



rezopia
FROM
SONATA SOFTWARE
TRAVEL SAAS

Reservation, Distribution, Contracts & Operations on one single Cloud Platform



Core features of MADP, MAM, MBaaS & APIs on a single, unified mobile platform



I.B.I.S. Inc.
A Sonata Software Company

Advanced Supply chain Software for Distributors, Manufacturers & Retailers



Big Data ready Retail Analytics Platform

Continuing to build, integrate and acquire platforms across Ecommerce, Analytics & DevOps to complete portfolio for 'Future Ready' IP led solutions.



Top SMB ERP Company
Cloud & Mobile engineering ERP for SaaS enablement

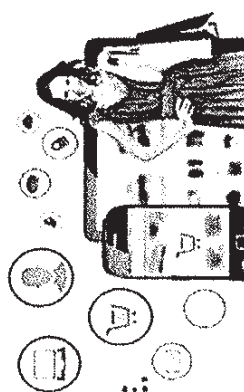

World Leading Retailer
Engineering Omni Channel retail systems on a new technology stack

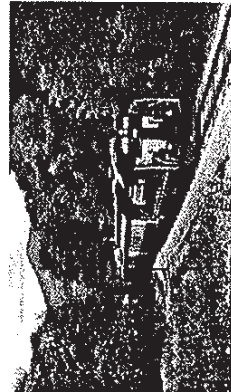

Top ANZ Rail Company
Enabling next-gen Rail reservation & ancillary services

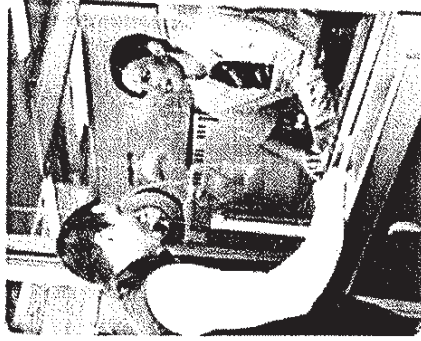

Business Need: Upgrade reservations systems across core Rail and ancillary package sales

Solution: Rezopia Travel SAAS customized to next-gen reservation systems

- Manage Services, Schedules, Inventory, Fares and Rules
- Multi-channel booking engine – web, call center, stations and agents
- Dynamic shopping cart with ancillaries like hotels, transfers and activities
- Integration to back end SAP ERP for Financial data integration

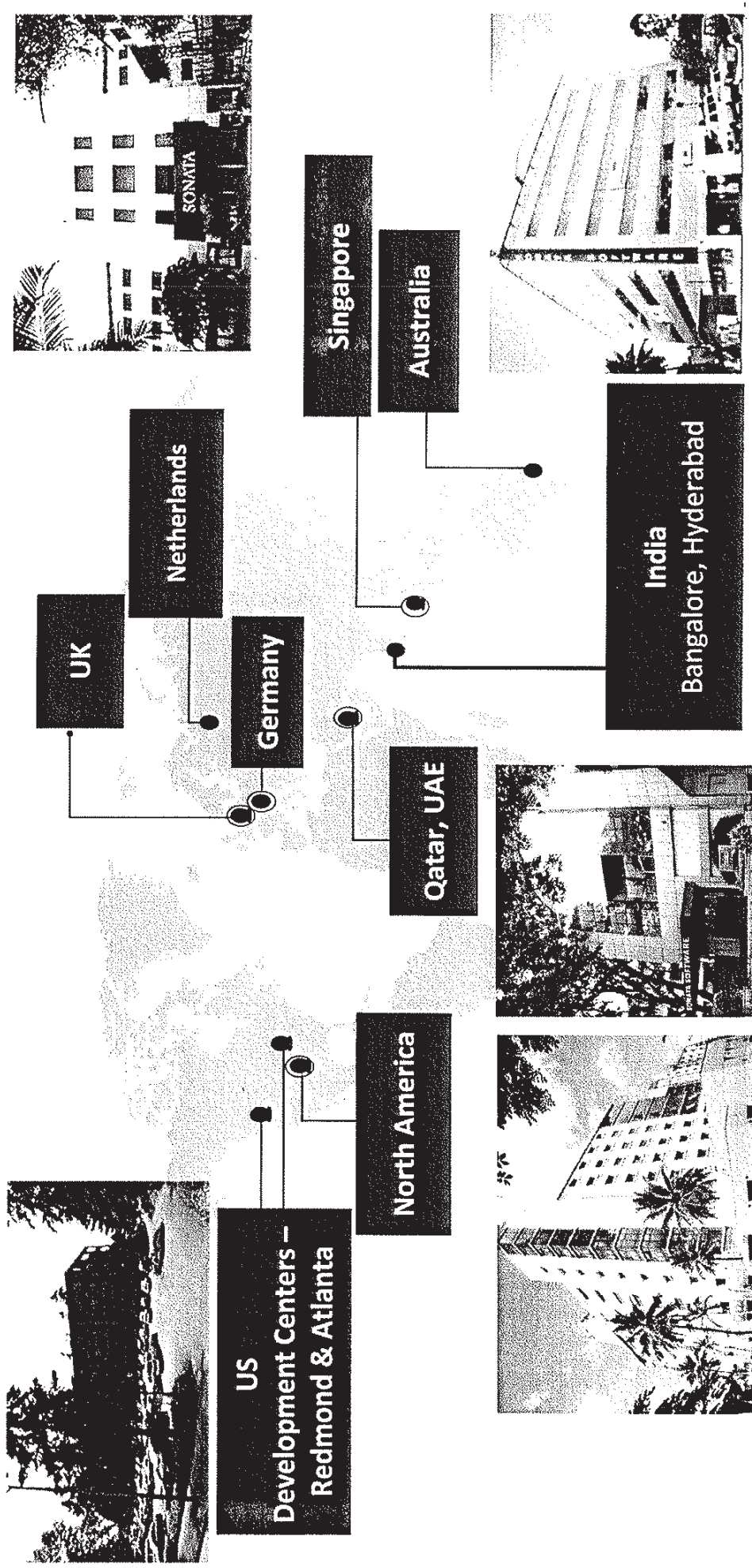



Technology Infrastructure

- Strategic partnerships with leading technology providers – Microsoft, SAP, Oracle, Appcelerator
- Relationships act an advantage in accessing emerging technology solutions
- High RoNW at >30% levels
- 360 degree footprint across Engineering, Implementation, Go to Market in IT value chain in key technologies – e.g. Dynamics AX

PORTFOLIO OF WORLD-CLASS ALLIANCES



**360 DEGREE CORPORATE
FOOTPRINT**
PE | PDS Implement | GTM
End to End Capability
on Technology Needs

**IN-HOUSE SOLUTION
CENTRE OF EXCELLENCE**
Expert Deployment Team |
Customer POC | Best
Practices Templates

**NEW TECHNOLOGY
ADOPTION**
SMAC | Platforms | Appliances
Cloud, MoovWeb,
Exadata

EXPERTISE | RELIABILITY | SPEED
in accessing technology solutions

**CORE IT
INFRASTRUCTURE**



- OS, Servers, Cloud & Virtualization
- Security, Identity & Access
- Infrastructure Management, Optimization & Support

**EMPLOYEE
PRODUCTIVITY**



- Communication & Collaboration
- Work Tools & Applications
- Onboarding & Support

**BUSINESS
APPLICATIONS**



- E. Comm, Digital Marketing, CRM, BI, Mobility, ERP, SCM
- IT Appliances
- Consulting & Support

Core Enterprise Infrastructure
migration to Cloud for cost optimization
Leading Brewery Company

Patient care enhancement thru collaborative work tools for doctors
Leading Hospital Chain

Enhanced business responsiveness thru next gen IT Appliances
Leading Bank



Financials



Description	For the Quarter ended			YoY
	30/Jun/16	31/Mar/16	30/Jun/15	
Revenues				
International IT Services	195.7	189.0	165.6	18%
Domestic- Products & Services	489.3	355.6	319.1	53%
Consolidated	677.8	540.9	479.2	41%
EBITDA				
International IT Services *	44.0	46.2	42.8	3%
Domestic- Products & Services *	15.3	14.9	14.4	6%
Consolidated *	58.5	60.4	56.2	4%
PAT				
International IT Services	28.0	32.3	29.8	-6%
Domestic- Products & Services	8.8	8.6	8.4	5%
Consolidated	36.8	40.8	38.2	-4%

* Includes "exceptional item" Interest income received on Income-Tax refund of Rs.2.08 crores in Q1 of FY2016-17 (of which relates to Rs.1.11 crore relates to and balance Rs. 0.97 crore to International), and Rs.2.72 crores in Q1 of FY2015-16 (relating to Domestic).

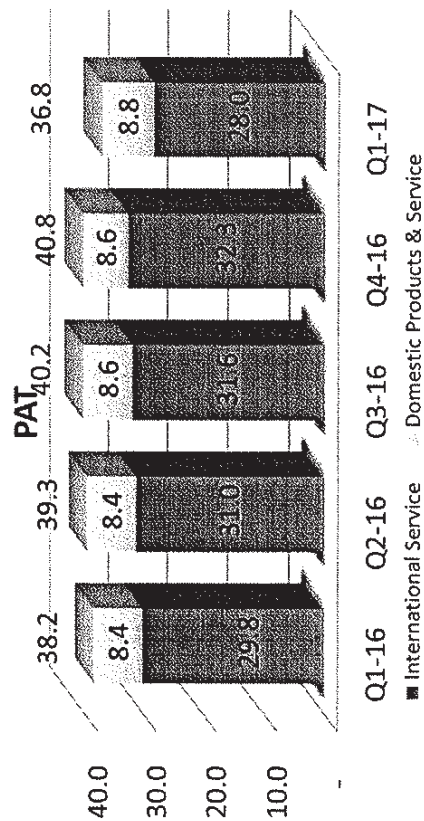
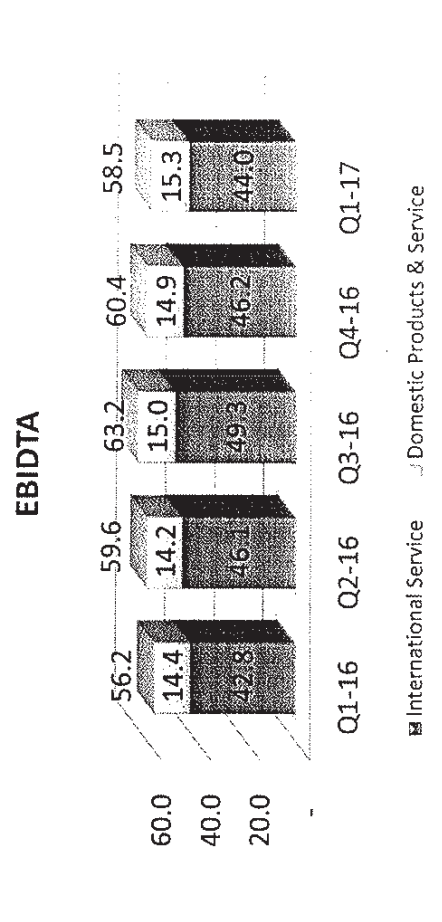
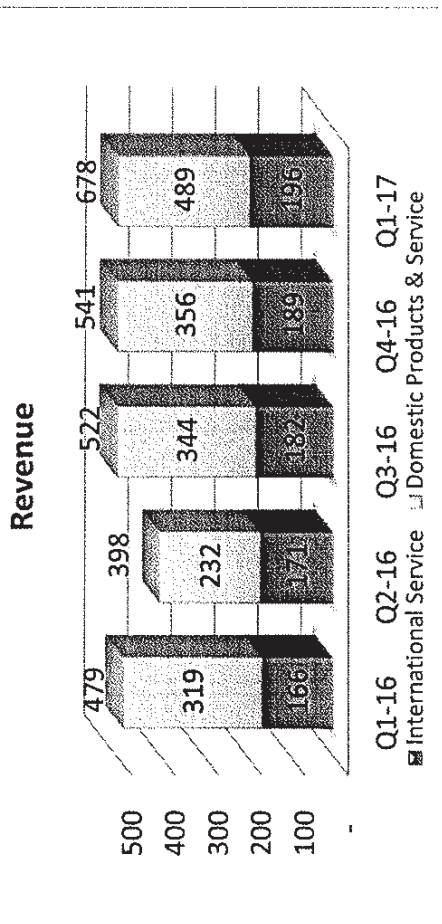

	QoQ	YoY
Revenue	25%	41%
EBIDTA	-3%	4%
PAT	-10%	-4%

Note : Q1-16 ,Q2-16 & Q1-17 EBITDA and PAT includes exceptional income of Interest on IT Refund

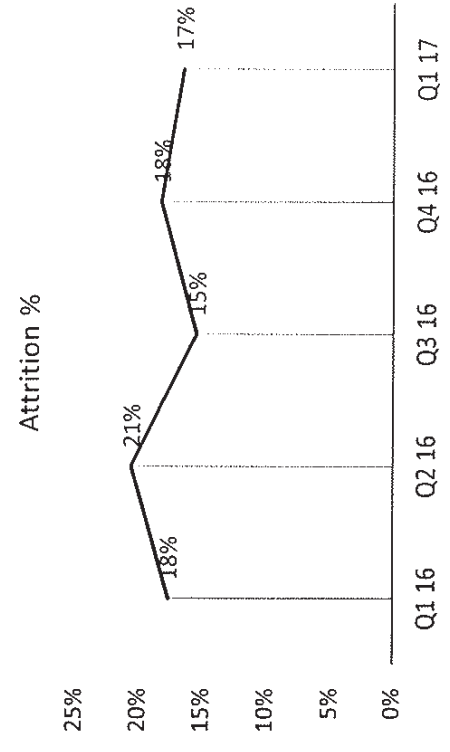
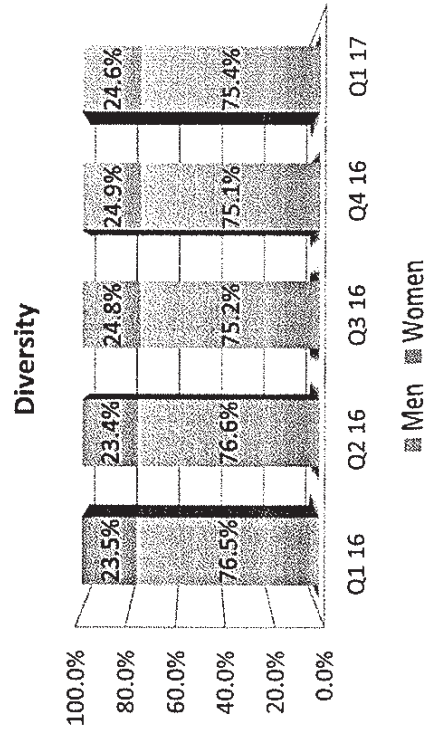
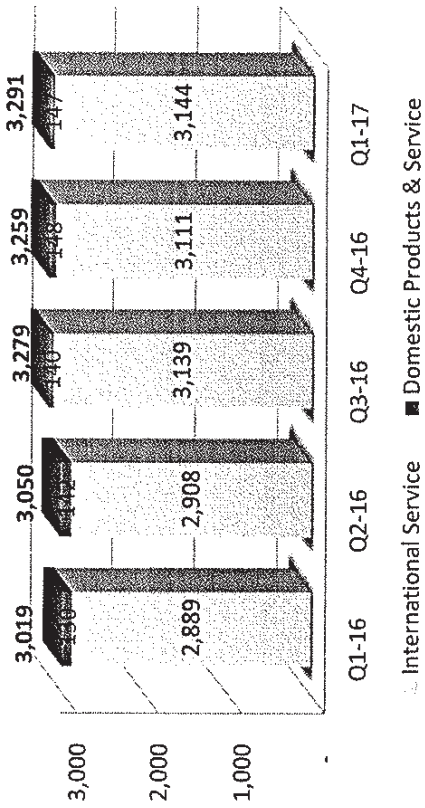

Revenue

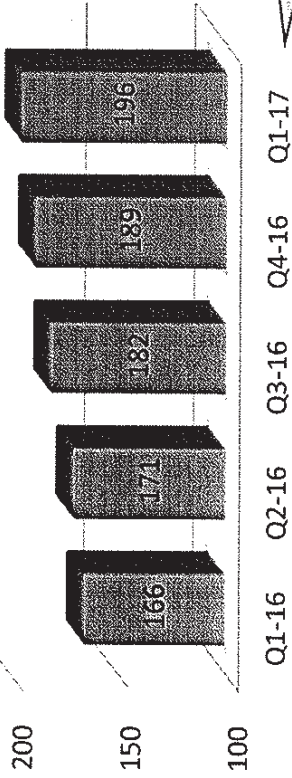

Rec'd Revenue

EBIDTA

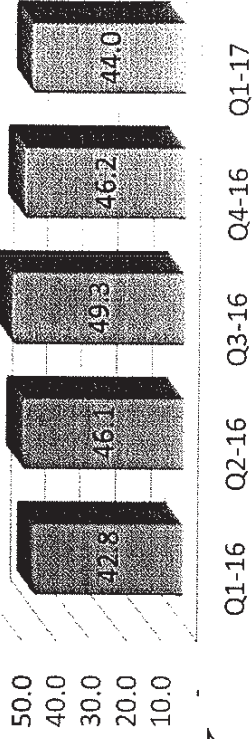

PAT

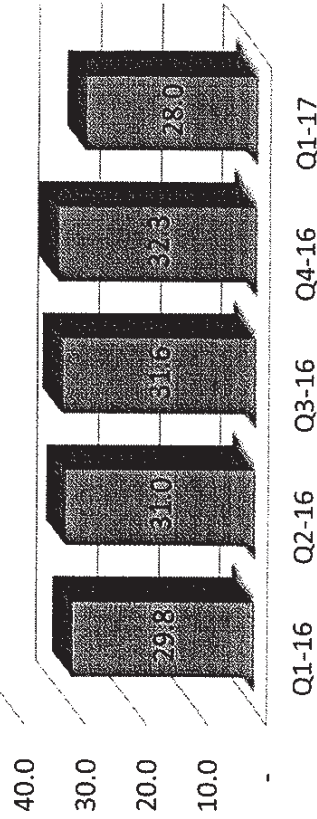

	Q1-16	Q2-16	Q3-16	Q4-16	Q1-17
Revenue	166	171	182	189	196
EBIDTA	42.8	46.1	49.3	46.2	44.0
PAT	29.8	31.0	31.6	32.3	28.0
	4%	-5%	-13%	18%	3%
					-6%

Note : Q1-17 EBITDA and PAT includes exceptional income of Interest on IT Refund

Revenue \$ mn

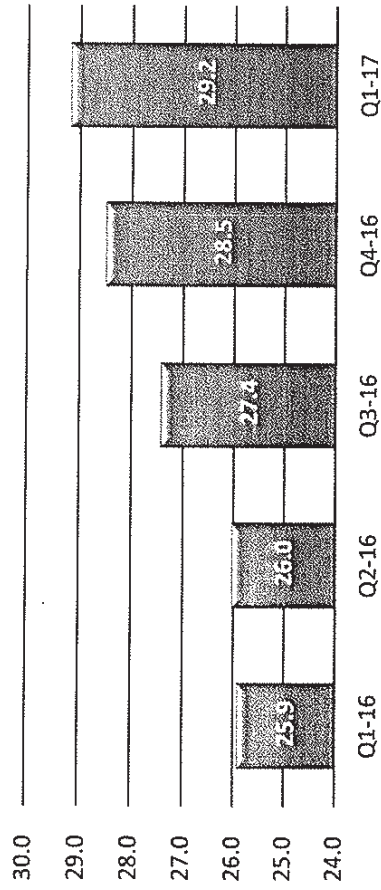

Geography

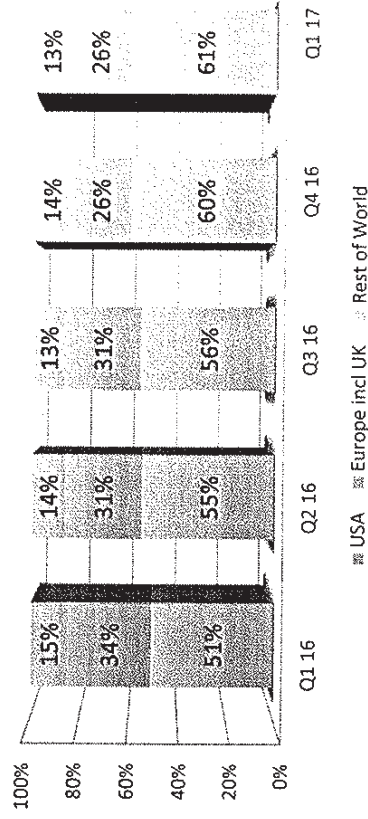

Onsite / Offshore

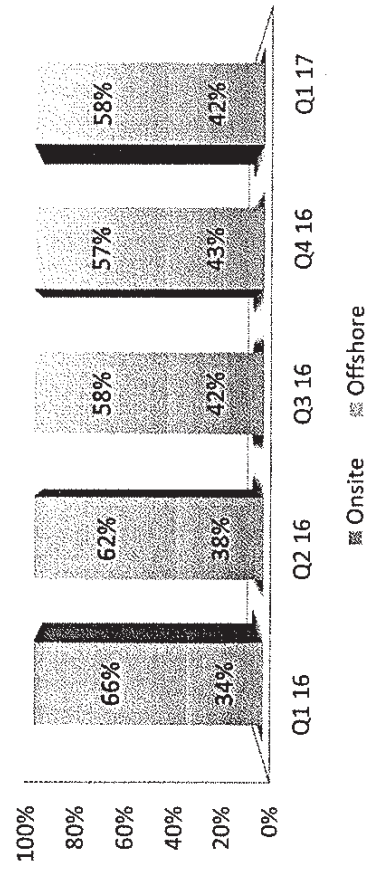

Vertical

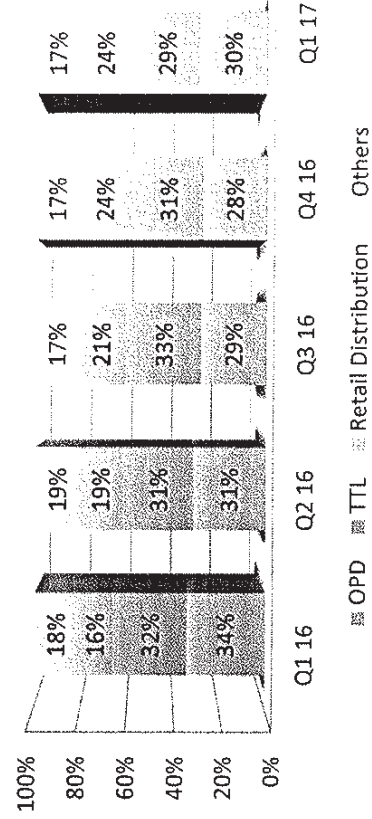

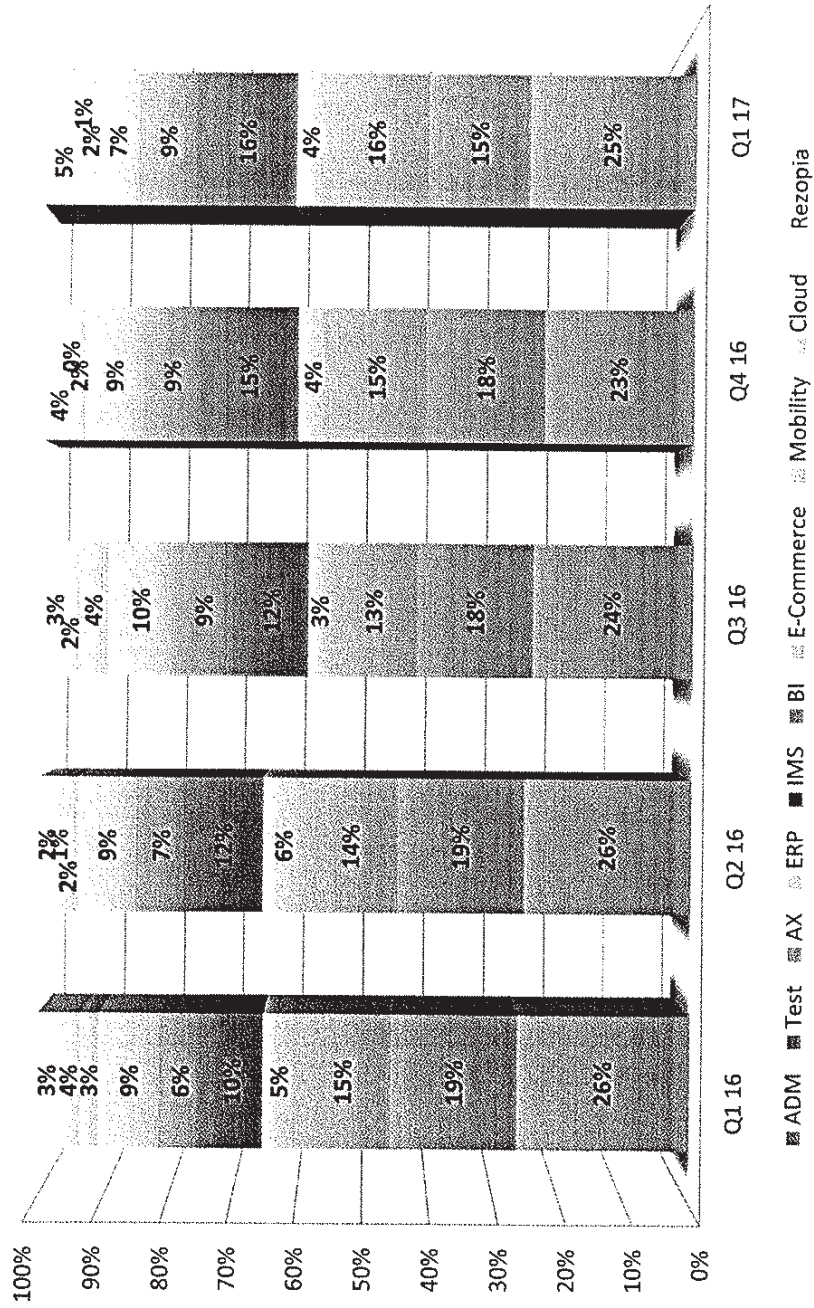
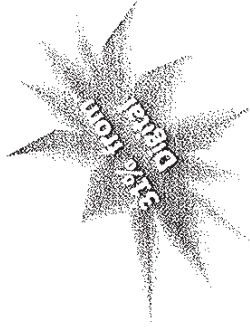

Note:-

1. Digital components includes revenue from BI, E-commerce, Mobility, Cloud, Resopia

New Customers

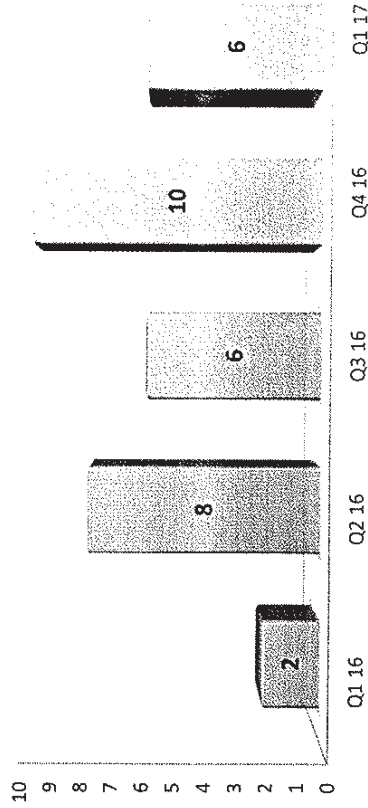

Customer Category

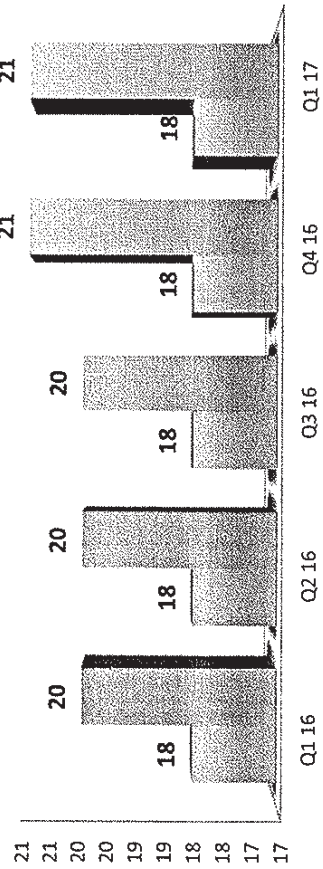

■ # of Fortune 500 accounts ■ # of million dollar clients

Revenue from Top 10 customers

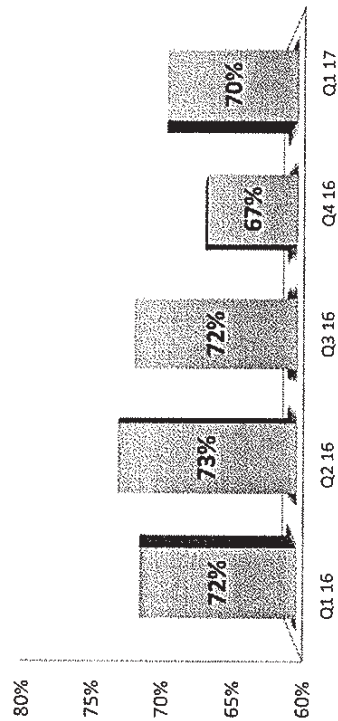

No. of customers by Geo

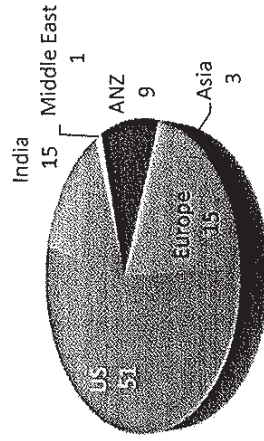

No. of customers by Vertical

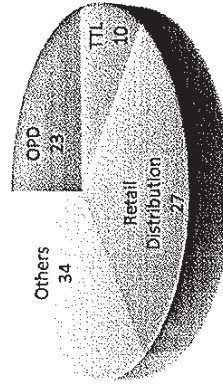

Revenue

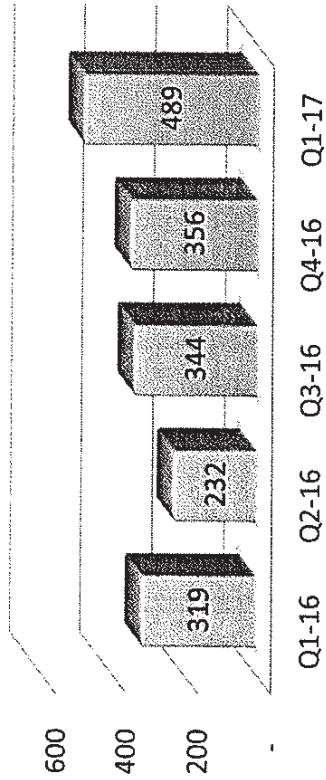

EBIDTA

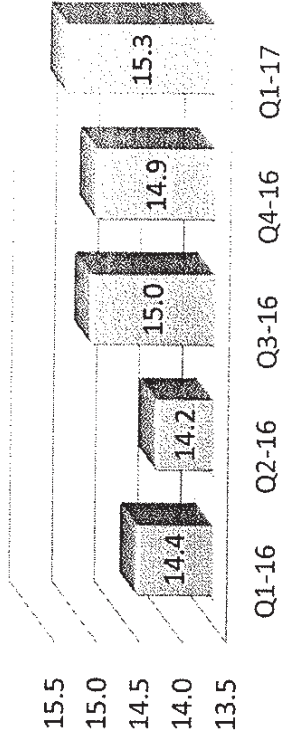

PAT

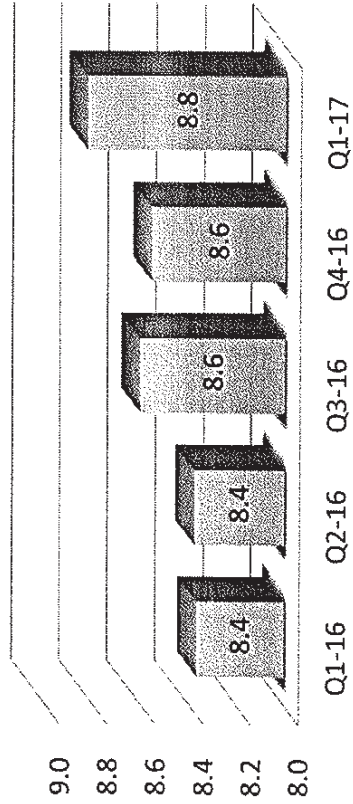

Q1-17	
Revenue	38%
EBIDTA	2%
PAT	3%

Note : Q1-16, Q2-16 & Q1-17 EBITDA and PAT includes exceptional income of Interest on IT Refund

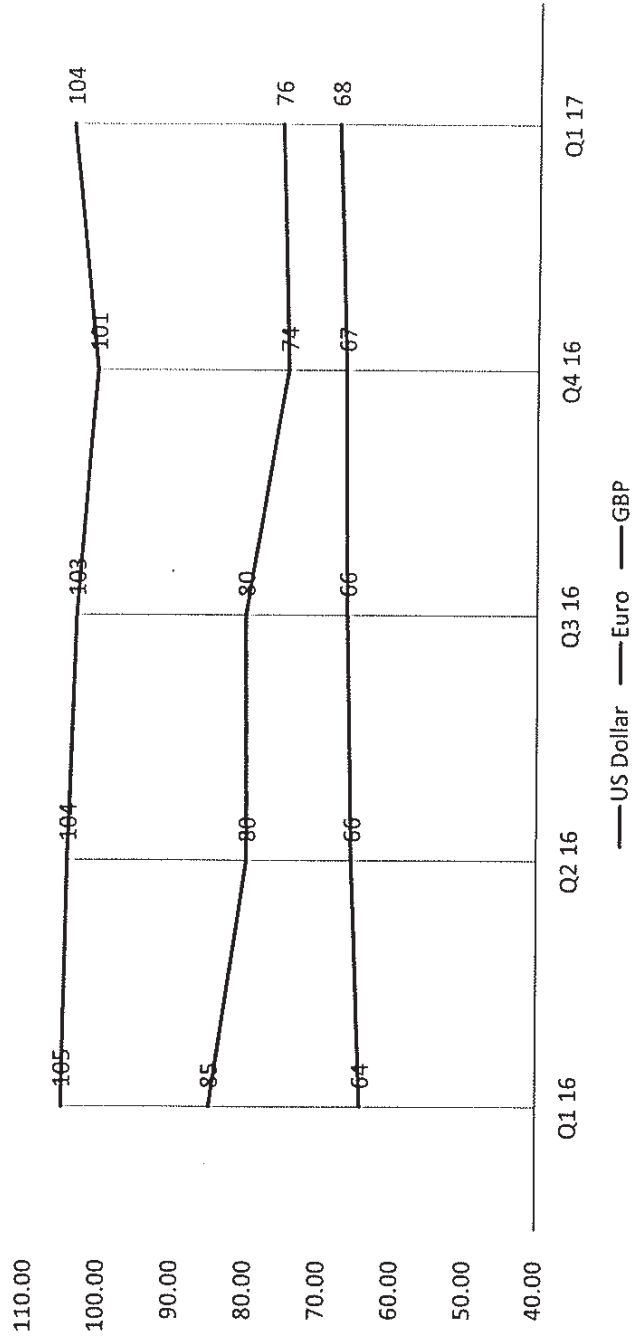

ROCE

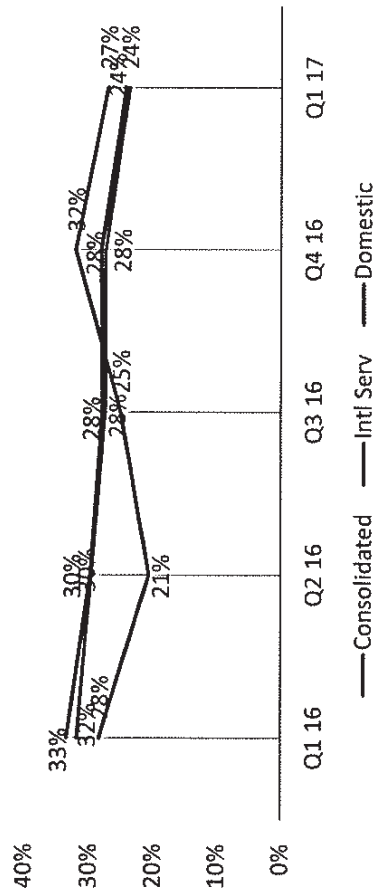

RONW

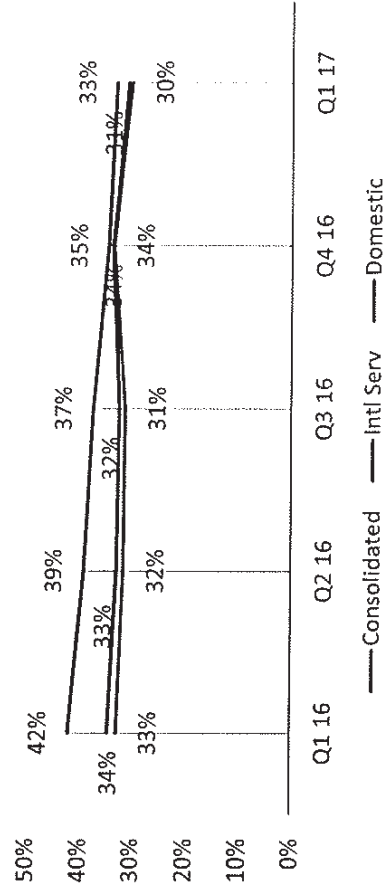

Consolidated

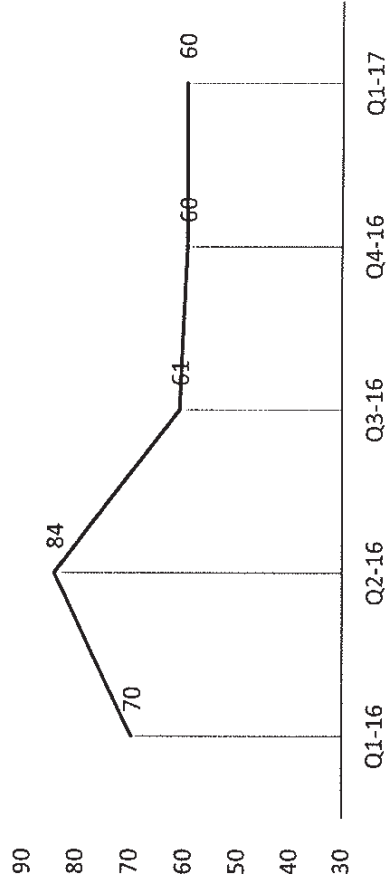

International Services

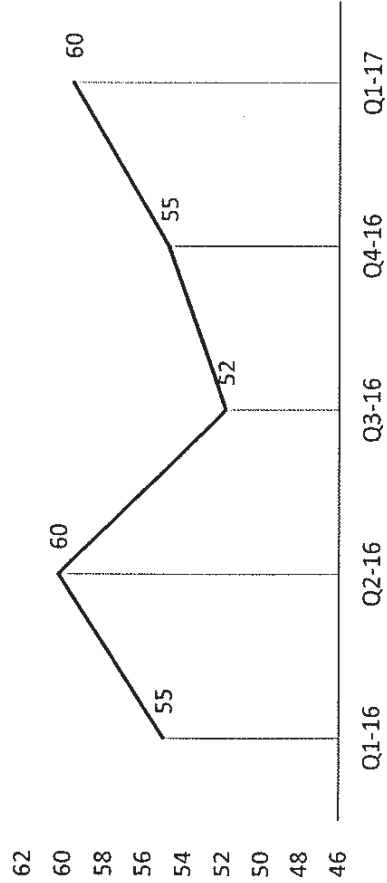

Domestic

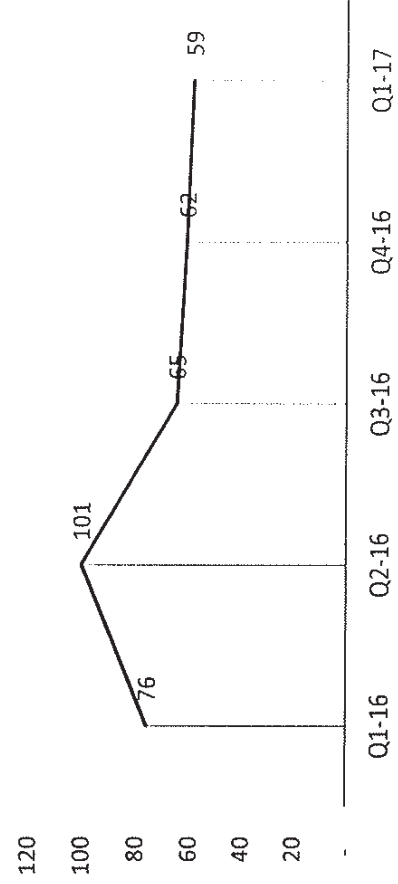

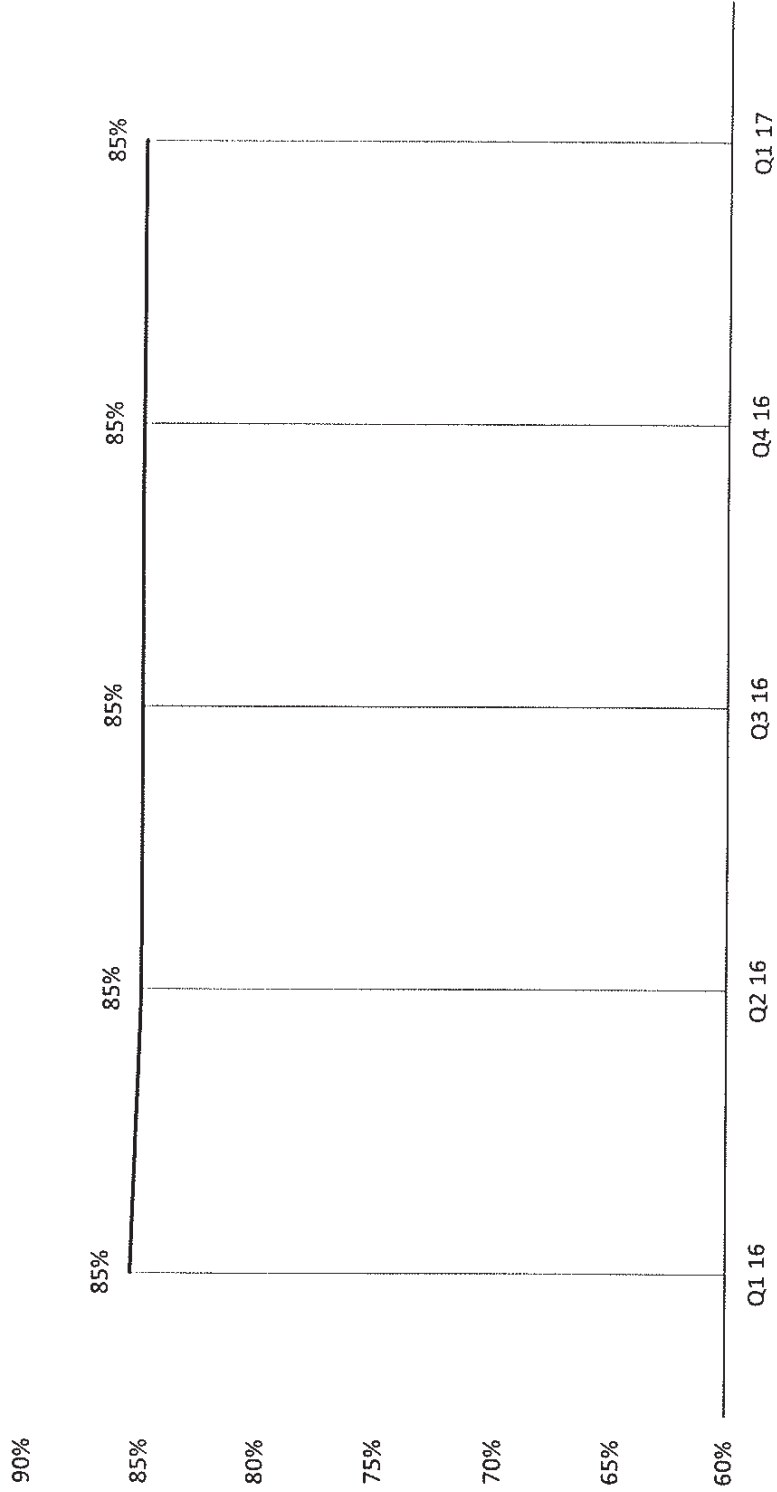

GO DEEPER

Transform business with IT



Thank You!



www.linkedin.com/company/sonata-software



www.facebook.com/sonatasoftware



www.twitter.com/sonata_software

www.sonata-software.com