

RAIL:SEC:2018

November 27, 2018

BSE Limited Phiroze Jeejeebhoy Towers Dalal Street Mumbai - 400001 Scrip Code - 520008	National Stock Exchange of India Limited Exchange Plaza, 5 th Floor, Plot No.C/1, G Block Bandra-Kurla Complex Bandra (E) Mumbai - 400 051 Scrip Code - RICOAUTO
---	--

Sub : **Presentation to Analysts on 27th November, 2018**

Dear Sir/Madam,

In continuation to our letter dated 26th November, 2018, please find enclosed the Presentation which will be made by the Company to the Analyst/Institutional Investor Meeting being held today. The presentation is also available on the website of the Company www.ricoauto.in.

Kindly acknowledge receipt and take the same on record.

Thanking you,

Yours faithfully,
for **Rico Auto Industries Limited**

B.M. Jhamb
Company Secretary
FCS : 2446

Encl : As above

The RICO logo is displayed in a bold, blue, sans-serif font. The letters are thick and modern, with the 'O' being a solid circle. The background of the slide is a photograph of a large, modern, multi-story office building with a curved glass facade and a blue sky with light clouds. The building has the RICO logo on its upper right side. In the foreground, there are three flagpoles with the Indian national flag and two white flags with logos. The building is surrounded by greenery and a paved area.

RICO

RICO AUTO INDUSTRIES LIMITED

A world class integrated supplier of Automotive
Components & Assemblies

Investor Presentation
November 2018

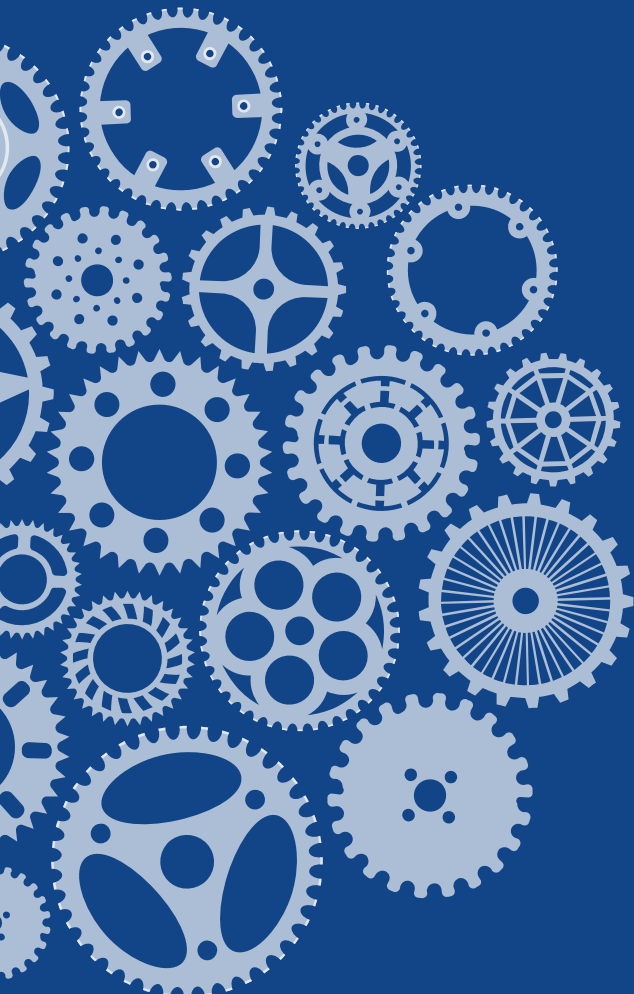

Company Overview	03
Board of Directors & Management	08
Organisational Structure	10
Group Revenue & New Business Won	11
Product Portfolio & Joint Ventures	15
After Market Business Highlights	23
Manufacturing and R&D Capabilities	26
Awards, CSR Activities & HR Initiatives	32
Financials	36
Stock Information	45



Incorporated in
1983



Global Supplier of
**Automotive
Components**



14
Manufacturing
Plants



Presence in
4 Continents



Over **4,500**
Employees



Strong in-house
R&D Capabilities



Turnover (FY18)
INR 1,230Cr



All Automotive
Certifications



**Joint
Ventures**

Magna Rico Powertrain Pvt. Ltd.
(Oil & Water Pump Systems)

Rico Jinfei Wheels Ltd.
(Alloy Wheels)



Preferred partner to OEMs

Client engagement from concept to completion stage

Strong in-house R&D capabilities.

Long-established relationship with OEMs.

Strategically located plants

Proximity of its plants to the OEMs.

Just in time approach

Last Mile Connectivity for overseas customers



4 decades of Execution Experience

Excellence in engineering critical products.

Strong focus on product & process innovation.



De-risked Business Model

Extensive product portfolio:

- Passenger vehicles,
- Commercial / Off Road Vehicles
- 2 Wheelers
- System Suppliers

Balanced business: Segments / Geography



E

ENTREPRENEURSHIP

The power of pursuing new challenges with speed, flexibility and ownership



T

TEAMWORK

The power of working together



I

INTEGRITY

The power of honesty and transparency



C

COMMITMENT

The power of responsibility, accountability and ownership



EX

EXCELLENCE

The power of being the best



Vision

To be the preferred supplier to OEM's across the globe.

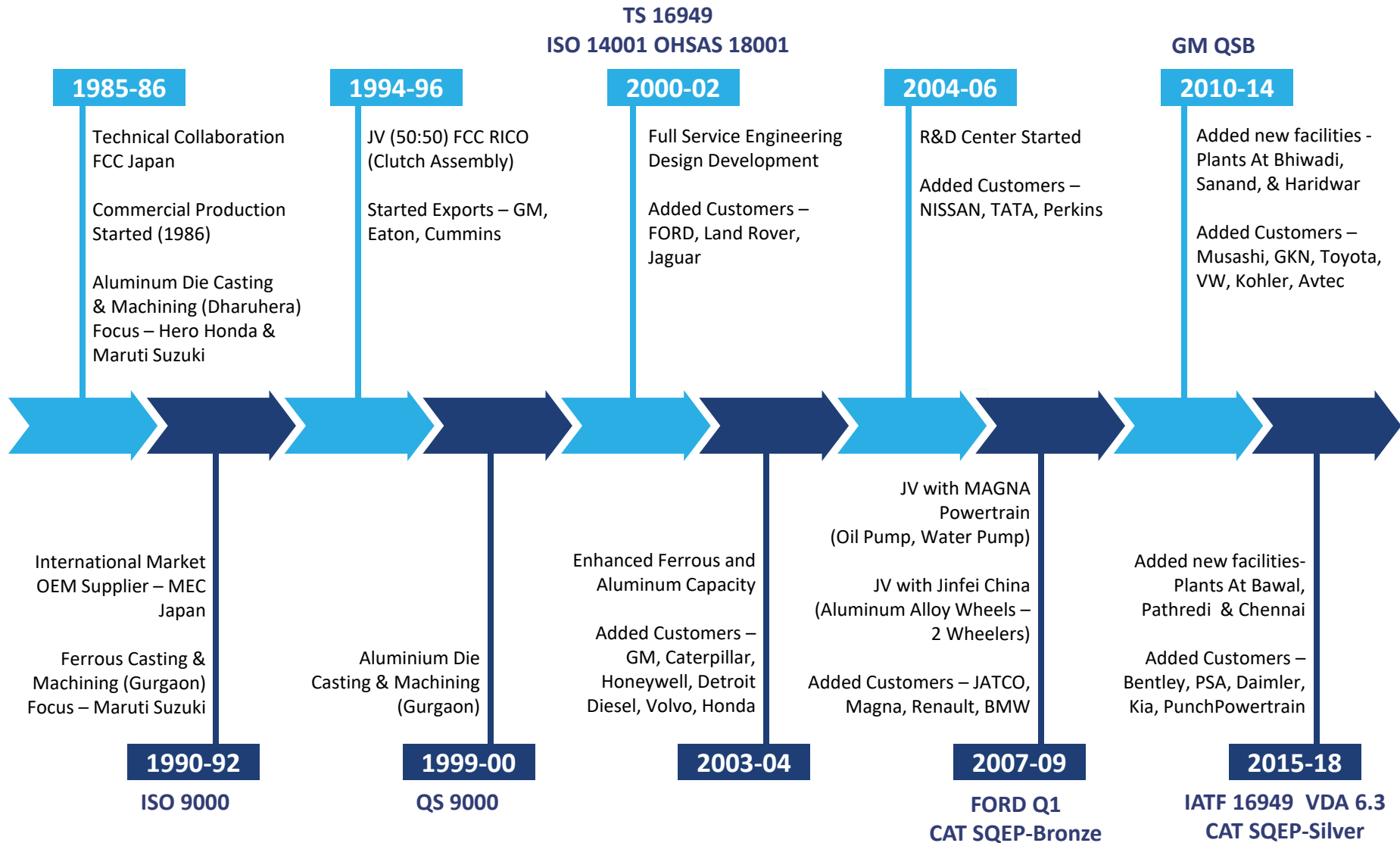



15 Acres

BAWAL
(Al. HPDC, Machining)



5 Acres

MANESAR
(Al. GDC, Machining)



12 Acres

BHIWADI / PATHREDI
(Machining)



27 Acres

GURGAON
(Corporate, R&D, Tool Manufacturing, Ferrous Casting, Al. HPDC, Machining)



5 Acres

DHARUHERA
(Al. HPDC, Machining)

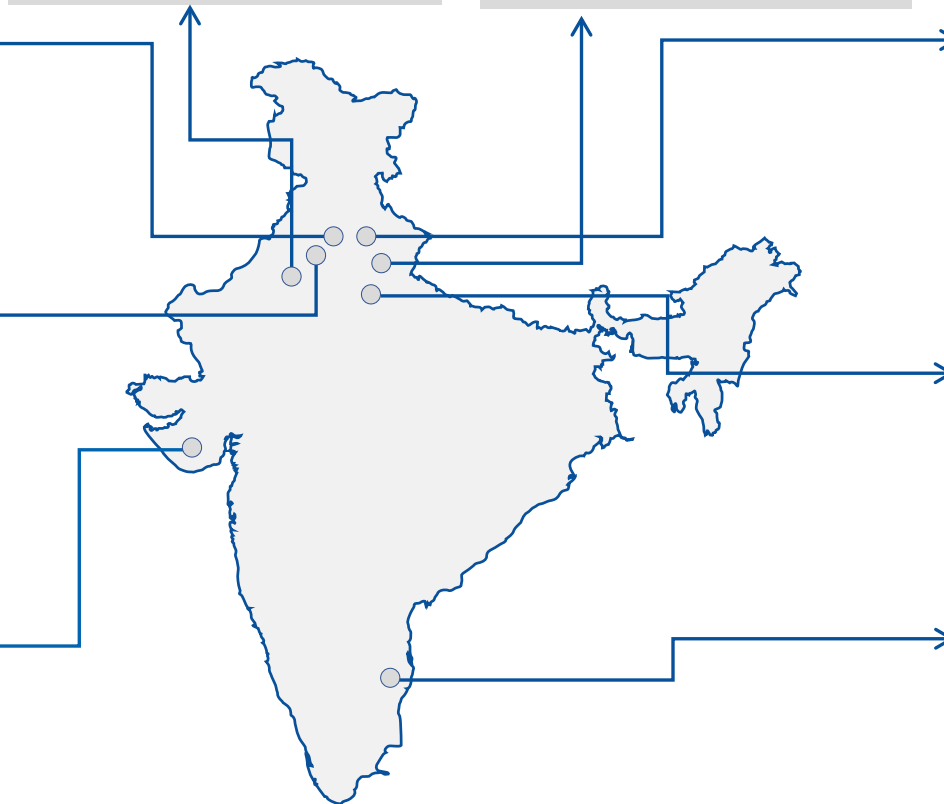

2 Acres

HARIDWAR
(Al. HPDC, Machining)



5.5 Acres

SANAND
(Al. HPDC, Machining)



12 Acres

CHENNAI
(Al. HPDC, Machining)



Arvind Kapur

Chairman, CEO & Managing Director



Kanwal Monga
Independent Director



Amarjit Chopra
Independent Director



Dr. Ashok Seth
Independent Director



Satish Sekhri
Independent Director



Rajeev Kapoor
Independent Director



Vinod Kumar Nagar
Independent Director



Rakesh Kapur
Non-executive director



Upasana Kapur
Non-executive director



Arun Kapur
Joint Managing Director



Surendra Singh
President & COO



Rakesh Sharma
Chief Financial Officer
Finance



R. K. Miglani
Vice President
(Operations & Engineering)



R. Dharna
Vice President
Operations



M. K. Jain
Chief Technical Officer



S. Kaul
Vice President
Operations



Sandeep Rajpal
Vice President
Marketing



Abhishek Kulshrestha
Vice President (Procurement,
Vendor Devp. & After Market.)



Subodh Mal
Associate Vice President
(Foundry & Tool Room)



Rajiv Kumar
Associate Vice President
(R & D / Engineering)

Advisory Committee



Sanjay Sharma
Chief General Manager
(Corporate Quality Head)



Neelam Dhaka
General Manager
(Corporate Human Resources)



N. K. Sethi
Management Advisor



O. P. Aggarwal
Financial Advisor



B. M. Jhamb
Company Secretary

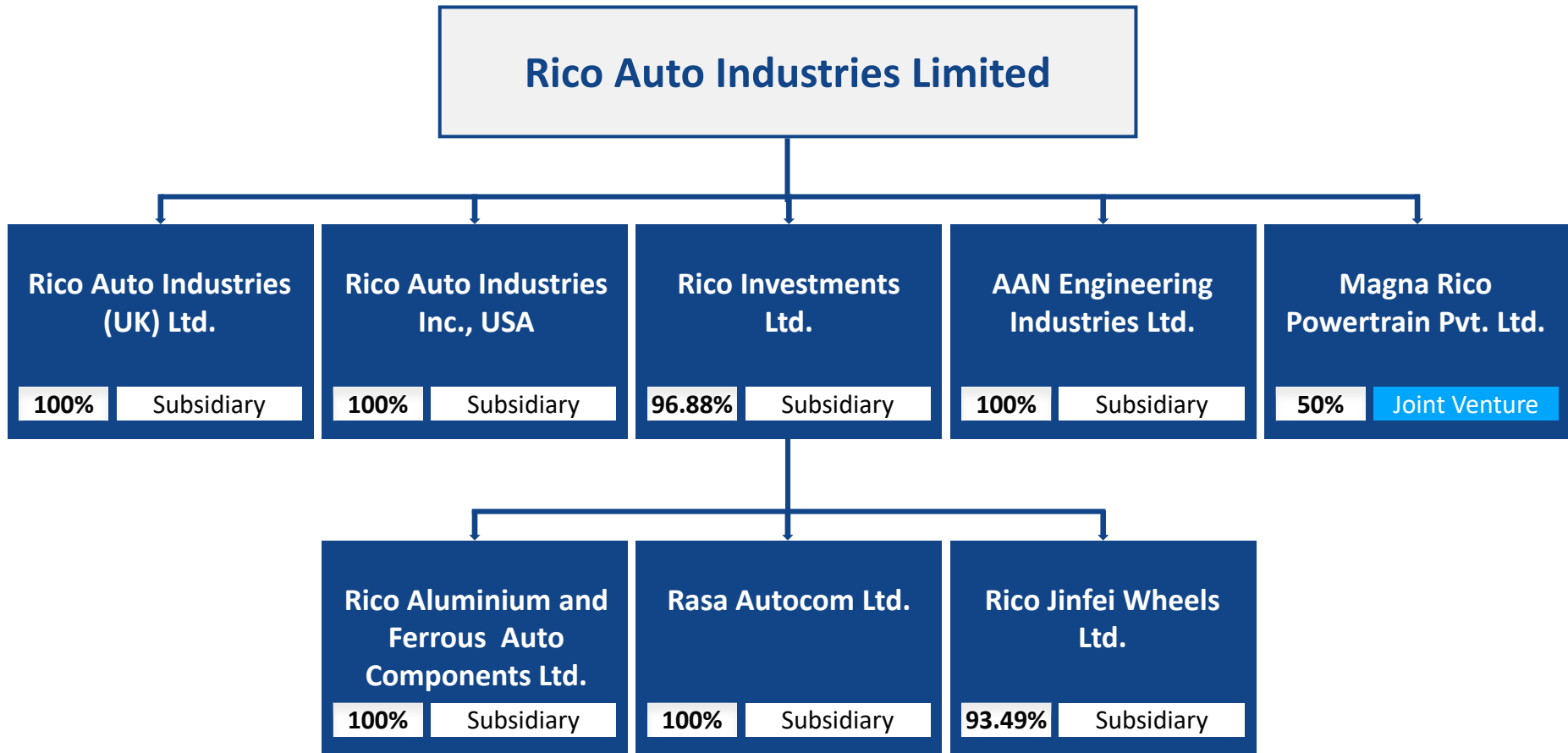

FY 2017-18 (Actual)

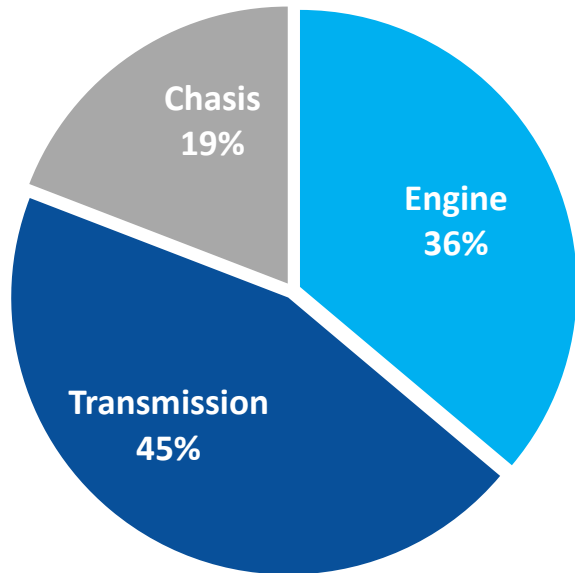

FY2020 (Expected)

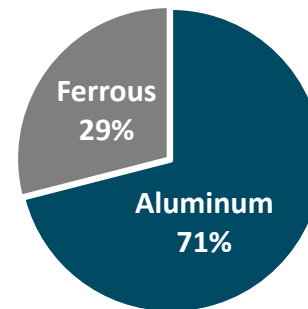
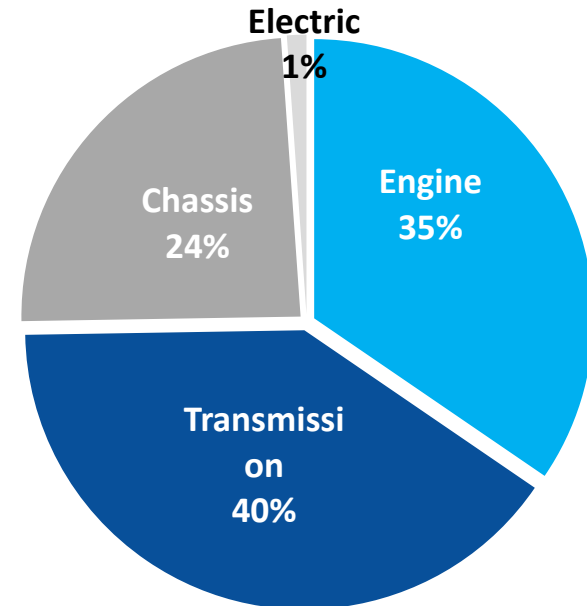



Program Value
441 Cr

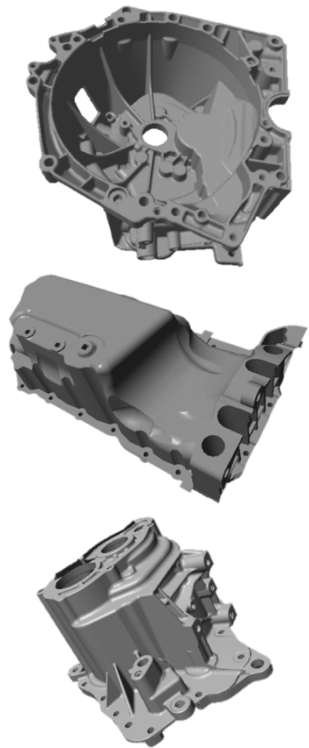

Program Value
425 Cr

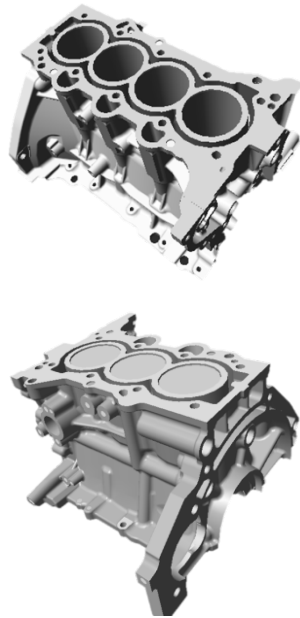

Program Value
180 Cr



Program Value
108 Cr

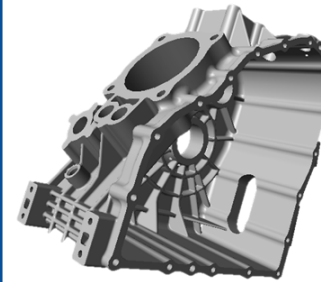

DAIMLER

Program Value
37 Cr





Program Value
INR 950 Cr

Program Value
INR 115 Cr

Program Value
INR 40 Cr

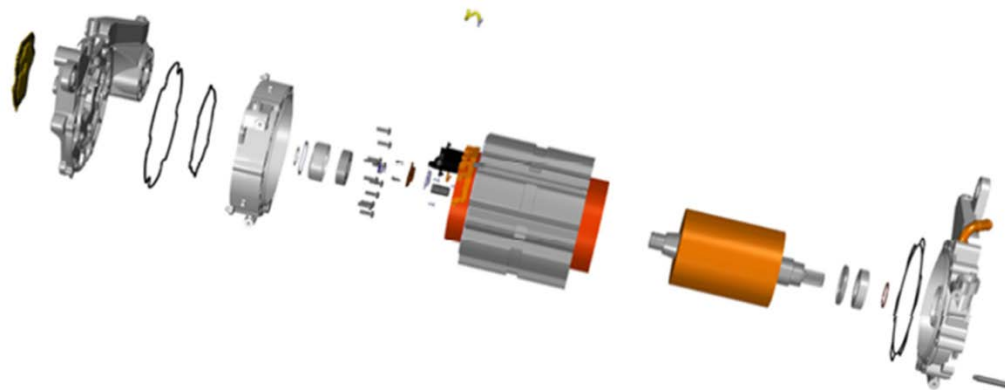



Program Value: INR 1200 Cr

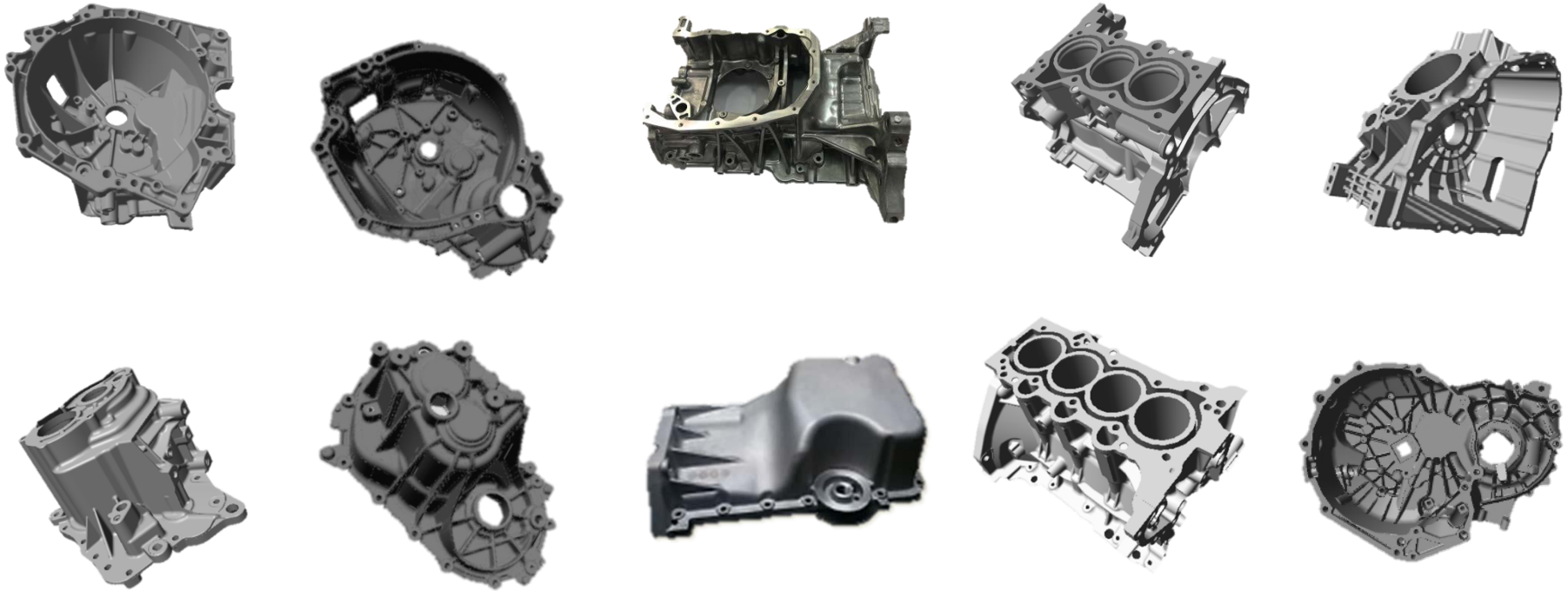

Product Portfolio



ALUMINUM CASTING



FERROUS CASTING



MACHINING AND ASSEMBLY



DIES AND MOULDS



DEFENCE EQUIPMENTS



ENGINEERING & R&D



Assy. Cover Cylinder Head
(Suzuki, GM)



Balancer Shaft
(GM)



Exhaust Manifold (Renault,
Nissan, Suzuki)



Turbine/ Center Hsg
(Nissan, Tata, GM, Suzuki, Fiat, Honda,
Ford, Hyundai)



Engine Block (Renault,
Tata, Kia)

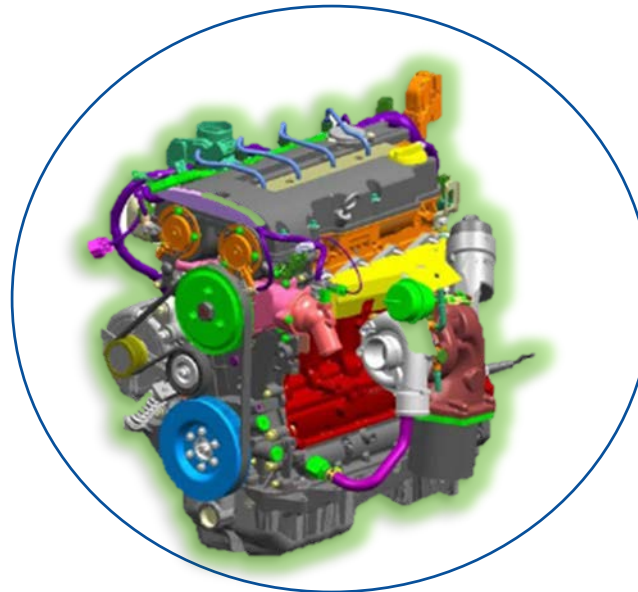

Case Chain/ Case Timing (Honda,
Renault, Suzuki)



Engine & Support Brackets
(Suzuki, Renault, VW, Volvo,
Toyota)



Oil Pan
(Suzuki, Honda, GM, Tata, PSA, Kohler)



Bearing Cap
(Renault, Nissan, Cummins)



Turbo Outlet
(Renault)



EGR Pipe
(Renault)

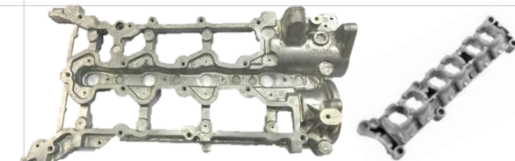

Cam Cap Support / Ladder Frame
(Renault, Suzuki)

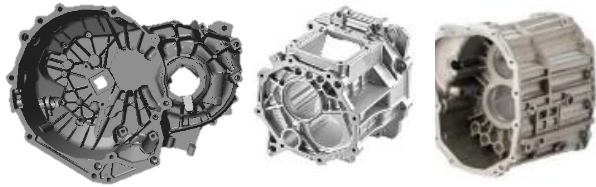

Transmission Case
(Eaton, Renault, Suzuki, Tata)



Clutch / Mechanical
Housing
(Renault, PSA)



Shifter Forks
(Suzuki)

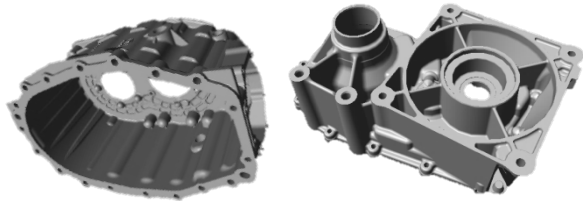

Front Diff Housing
(Tata, Renault)

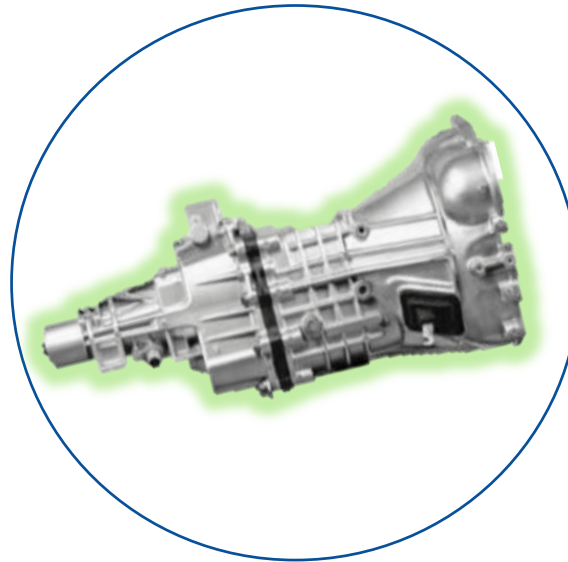

Ground Sleeve & Shaft
(Allison)



Differential Case & Housing
(BMW, GKN, Suzuki, Ford, Honda)



Retainer Bearing Support
(Jatco, PunchPowertrain)



Front & Rear Hubs



Front & Rear
Brake Panel Assy



Crank Cases



Clutch Assembly



Grips

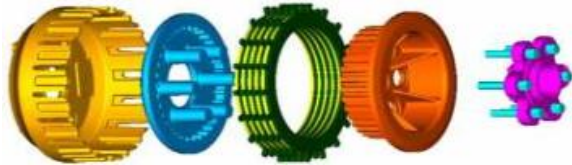

Engine Cover



Alloy Wheels



Joint Venture

50% : 50%

Year	FY 15-16	FY 16-17	FY 17-18
Oil & Water Pump Assy (Nos in Mn)	1.21	1.46	1.55
Turnover (INR Cr)	68	87	94



Client:





Joint Venture

93.49% : 6.51%



Aluminum Alloy Wheels (Two Wheelers)

Year	FY 15-16	FY 16-17	FY 17-18
Alloy Wheels (nos. in Mn)	0.85	0.96	1.12
Turnover (INR Cr)	79	84	114

Capacity Expansion Plan

3 Mn : Dec 18

4 Mn : July 19

Client :





AAN Engineering Industries Ltd.



Year	FY 15-16	FY 16-17	FY 17-18
Turnover (INR CR)	0.3	3.7	4.1

Arms Licence for the Manufacturing of Ammunition

- Aerial Ammunition 50 Cr spread in 3 years by Aug 18
- Mechanical Fuses – under bidding Dec 19 – 2500 Cr program value spread over for 10 years
- Electronic Fuse Assemblies – under bidding Dec 2019 – 3500 Cr program value spread over for 10 years
- Track-links

Client :



ECIL



OF Muradnagar



OF Khamaria



Prototype Tool Factory

After Market Business Highlights

Initiated on
20th May'2017

Product Range
2W and 4W

52 Dealers
(20+ States in India,
Srilanka & Nepal)

Parts launched
191+ (2W Range)



HIGH Durability
Accuracy
Reliability
Precision CNC Manufacturing

Total Revenue (in Cr.)

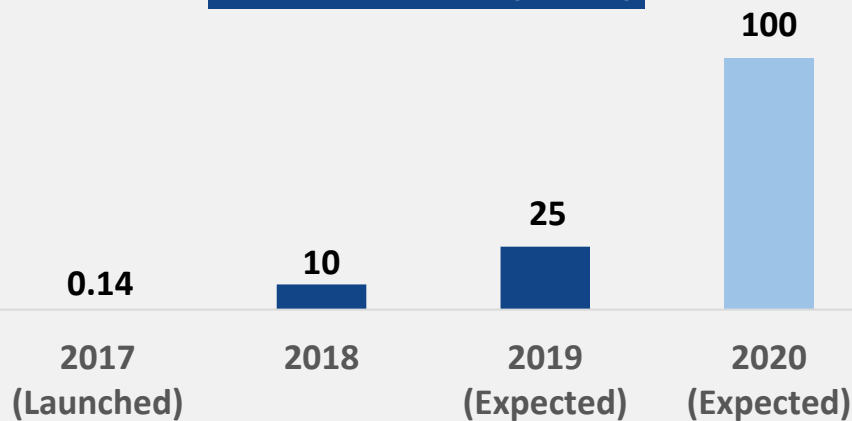

Launch Of 4W Parts in Q2FY19



WHEELS & BRAKING SYSTEMS



CLUTCH ASSEMBLY & COMPONENTS

New Products



LEVER



YOKE



CHAIN SPROCKET



CLUTCH HUB & CENTRE



INNER CLUTCH ASSEMBLIES

Manufacturing and R&D Capabilities



**Over 100 High Pressure Die Casting Machines (upto 2700 Tns Locking Force)
Largest High Pressure Die Casting Capacity in India including GDC & LPDC.**



**4 Molding Lines - 2 DISA & 2 Horizontal (SINTO & DISA)
Vertical Size (650 * 535 * 130~330) & Horizontal Size (610 * 510 * 200+200)
Material: Gray (FC), Ductile (FCD), SiMo, SiMo Chrome**



**Over 2000 Machines (CNCs & SPMs)
One of the Largest Machining Facility in India
Over 50% of Our Product Range is with Assemblies**

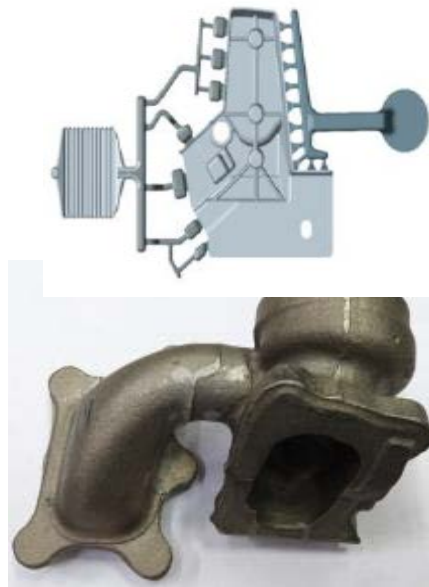

- ◆ 100 + New Projects
- ◆ 25 New Engineers added
- ◆ Expansion of Engineering set up to Bawal & Chennai
- ◆ Prototype Cell Created
- ◆ Pool of machines
- ◆ 3D Printing
- ◆ Concurrent Engineering
- ◆ High Strength Aluminum Alloy
- ◆ Structural Parts
- ◆ Stainless Steel Turbine

Combined Braking System (CBS)

Mandatory : 1 Apr 2019 for 2W

Rico SOP: Dec' 18

Co-Development with Hero R&D

Safety Sub-System

Capacity: 13000 / day

Automated Assembly Line



Clutch

New BSVI Clutch Development

Concept to Production

Rico SOP : Apr' 19

New CFD developed under validation

New paper based CFD for higher CC also under development by Jul' 19



Continuous Variable Transmission (CVT)

Massive growth in 2W

JV under advanced stages of negotiation with Taiwanese

Technology leader

SOP : Oct' 19

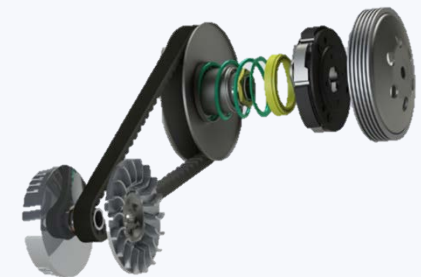

Awards, CSR Activities & HR Initiatives

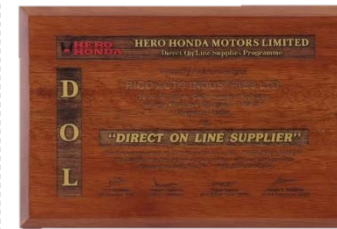
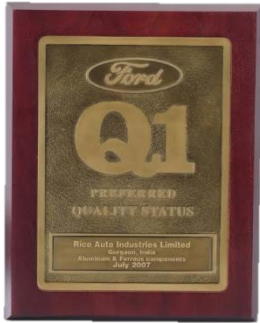



Enhancing Environmental Sustainability



Supporting Rural Development



Providing Preventive Health Care



Promoting Girls Education & Skill Development



Promoting "Cleanliness & Sanitation" in Rural areas



Induction Training – “Parichay”



Company Wide Training – “Jagriti”



Kaizen Award Ceremony



Best Work Place - Competition



Family Connect Program



Employees Children Safety Competition



Sports Competition



Yoga Training



Health Awareness Camp



Long Service Awards

Financials

Revenue

1230 Cr



10%
(YOY)

Net Worth

563 Cr

EBITDA

150 Cr



18%
(YOY)

RONW

10.7%

PBIT

96 Cr



18%
(YOY)

ROCE

12.0%

PBT

70 Cr



11%
(YOY)

EPS

4.3

PAT

58 Cr



12%
(YOY)

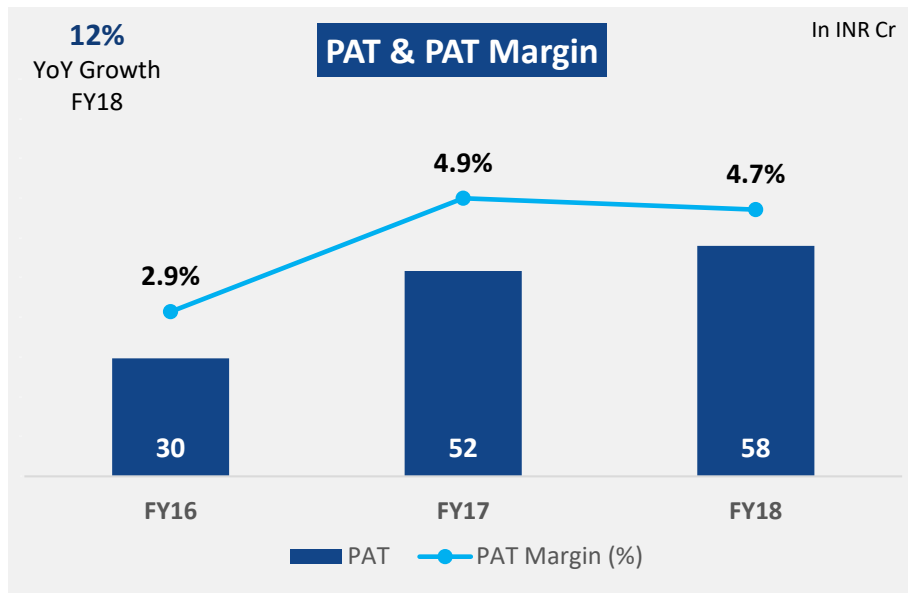
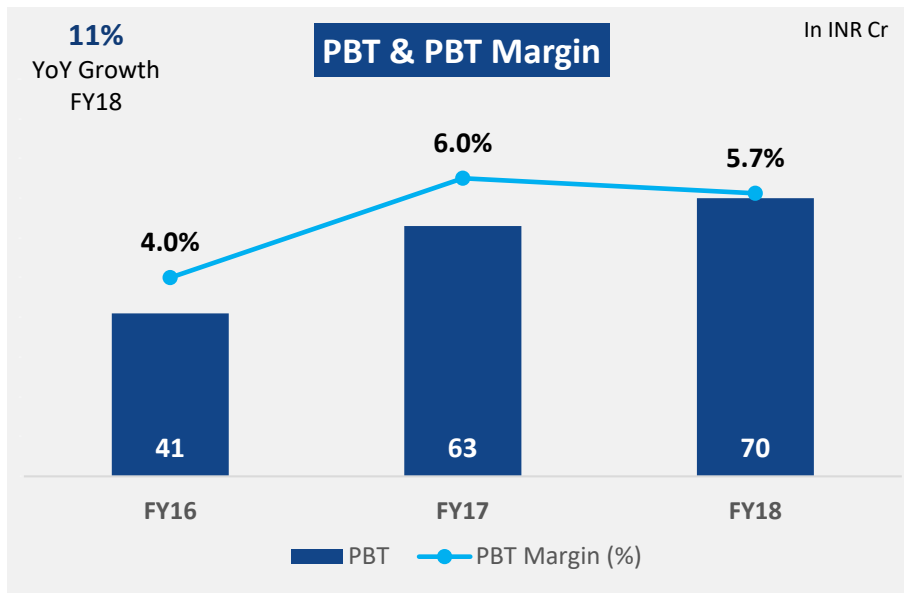
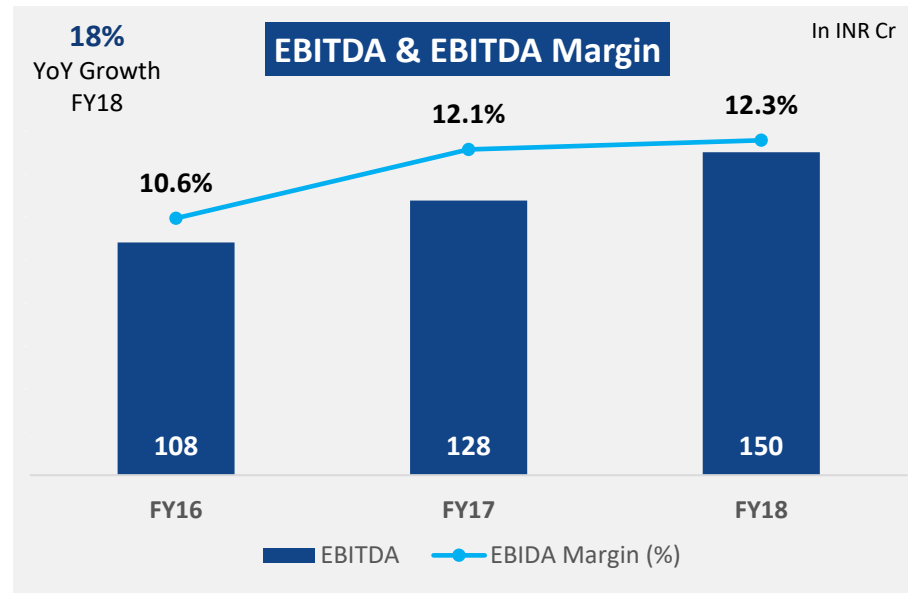
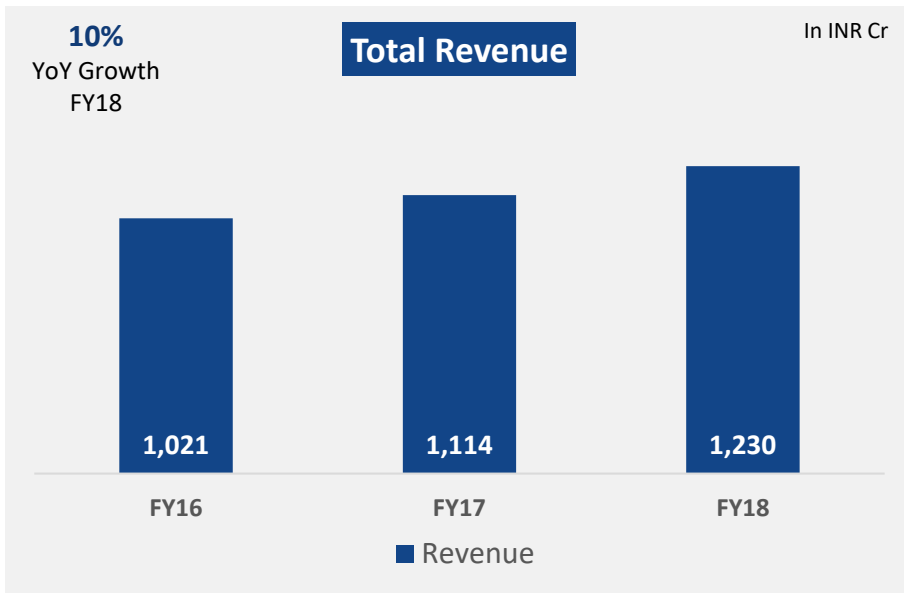

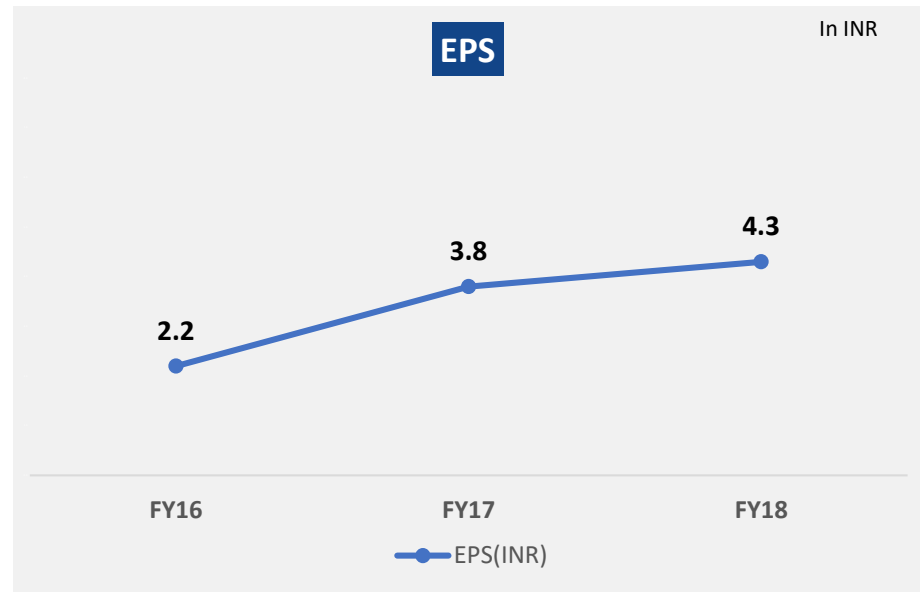
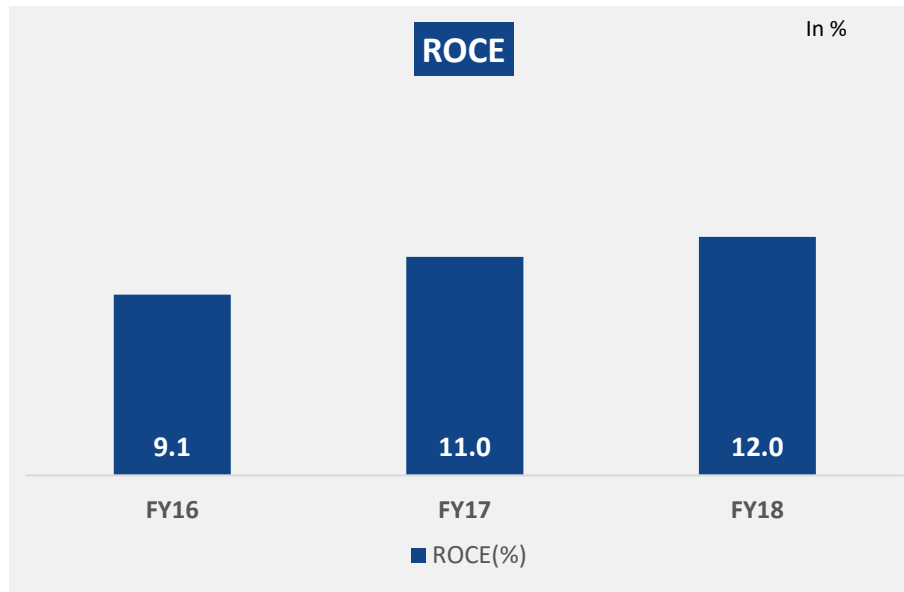
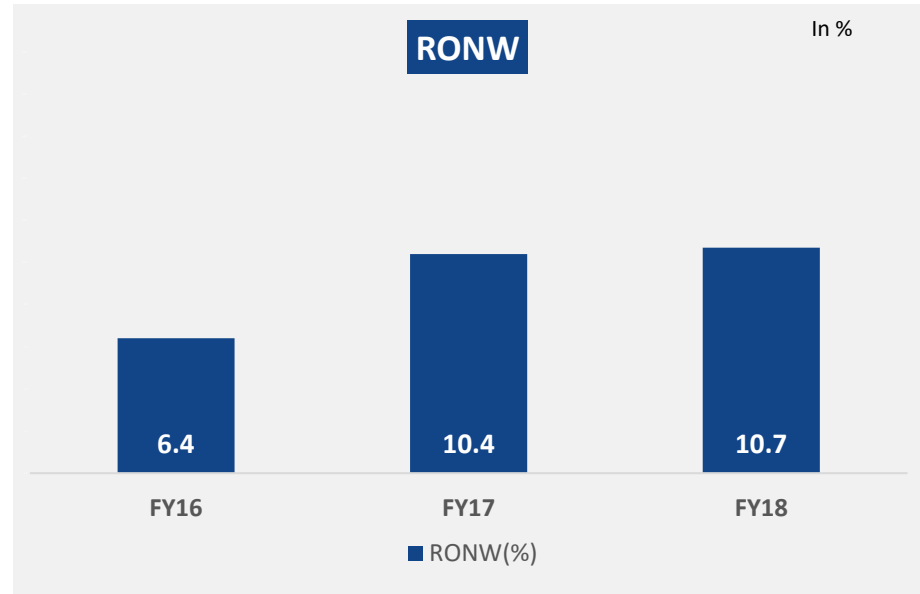
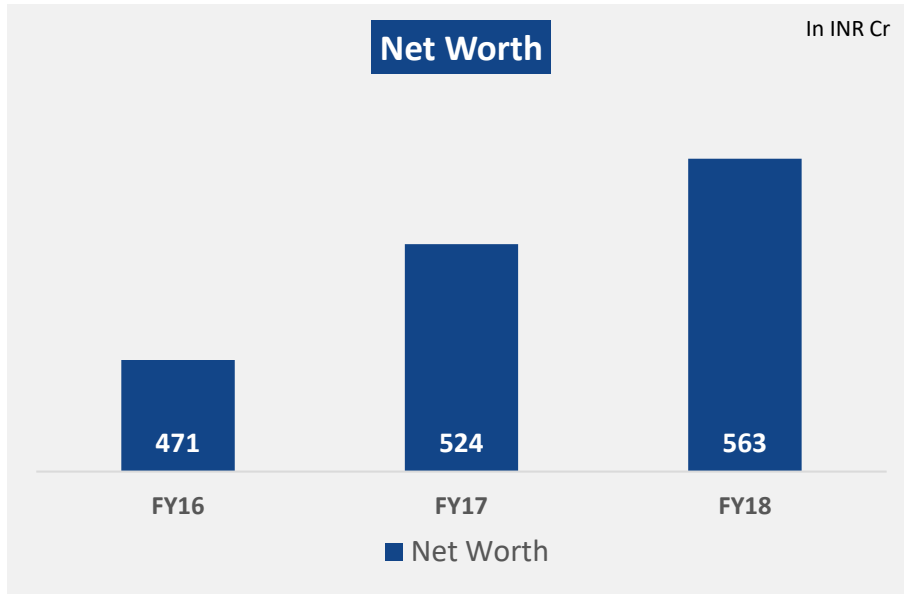

In INR Cr			Particulars	Consolidated		
YoY(%)	FY17	FY18		FY18	FY17	YoY(%)
7.2	1020.2	1093.2	Revenue from Operations	1229.6	1113.9	10.4
13.6	22.0	25.0	Other Income	16.1	13.3	21.1
7.3	1042.2	1118.2	Total Revenue	1245.7	1127.2	10.5
6.7	928.5	990.3	Total Expenses (Excl. Dep.& Interest)	1098.5	1002.5	9.6
12.5	113.7	127.9	EBITDA*	150.1	127.7	17.5
14.9	35.6	40.9	Depreciation	53.9	46.3	16.4
11.4	78.1	87.0	EBIT	96.3	81.4	18.3
7.5	16.0	17.2	Interest	18.7	16.7	12.0
2.8	61.4	63.1	PBT	70.1	63.4	10.7
-1.5	13.7	13.5	Tax	12.1	11.7	3.4
4.0	47.7	49.6	PAT before Minority Interest	58	51.6	12.4
-	-	-	Minority Interest	0.2	0.03	566.7
4.0	47.7	49.6	Net PAT	57.8	51.6	12.1

*Including profit from JV (2018 = 2.90 Cr, 2017= 3.04 Cr.)

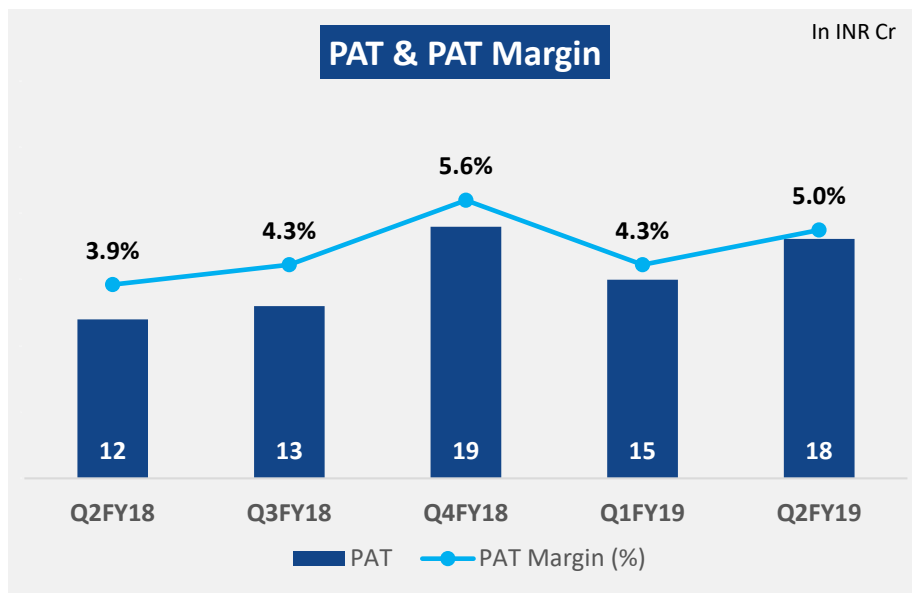
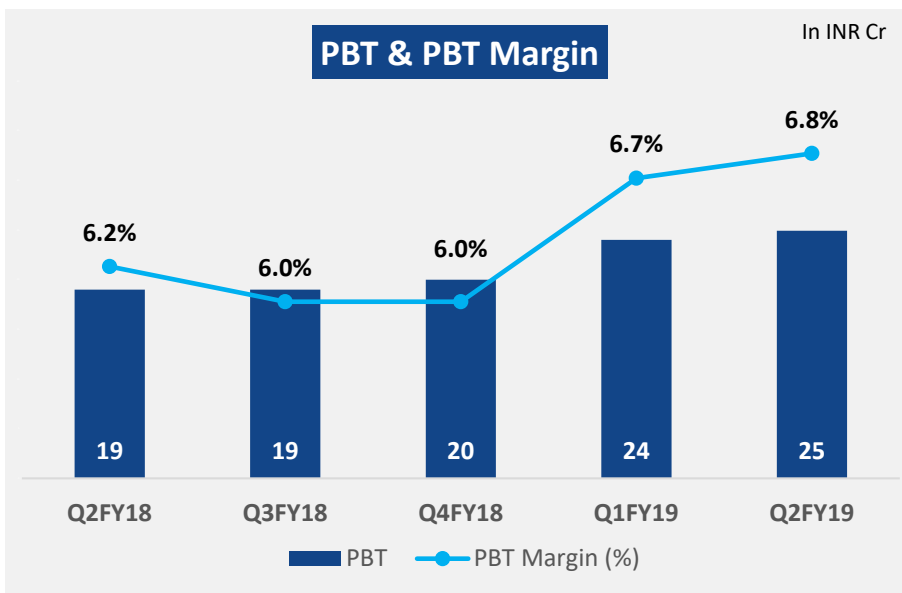
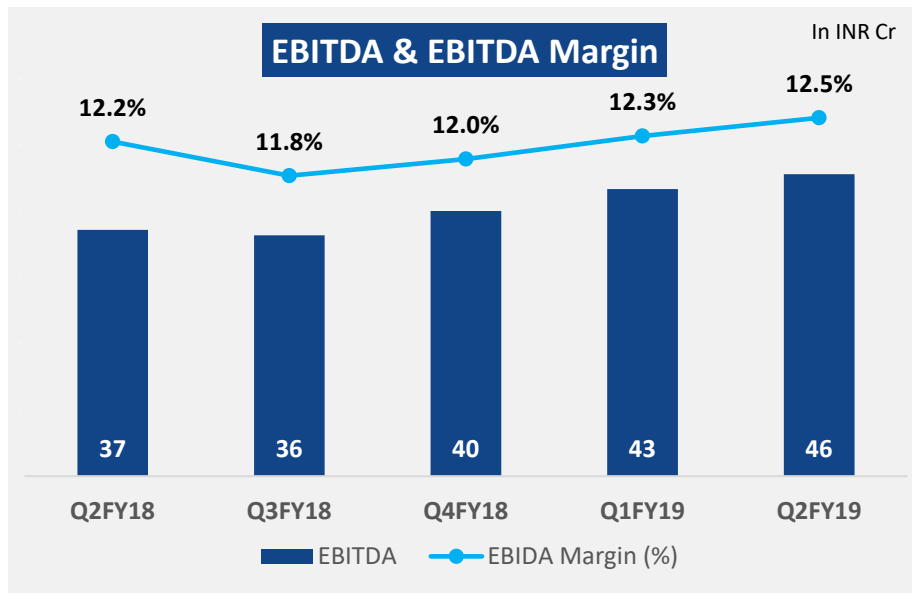
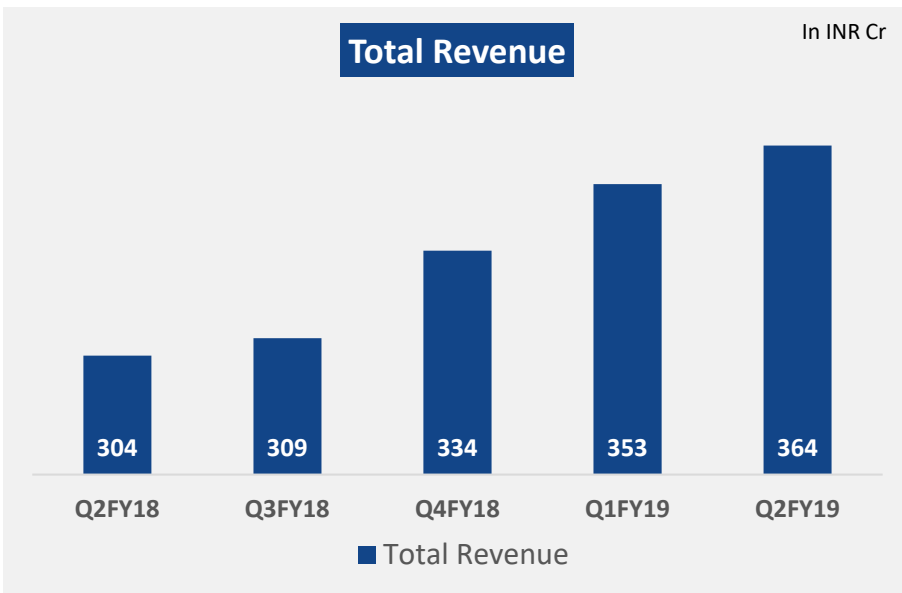

Total Revenue

In INR Cr

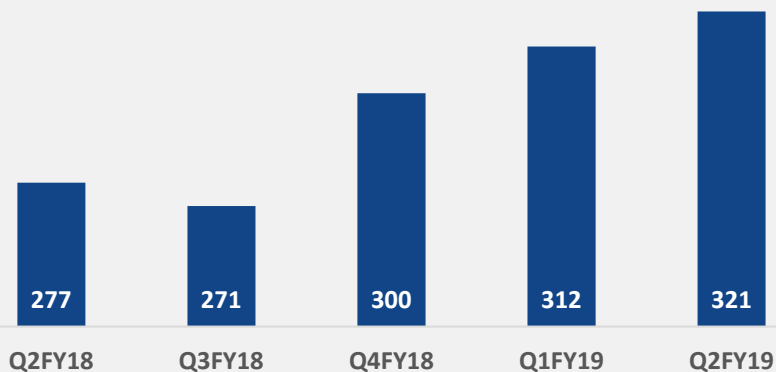

■ Net Operating Revenue

EBITDA & EBITDA Margin

In INR Cr

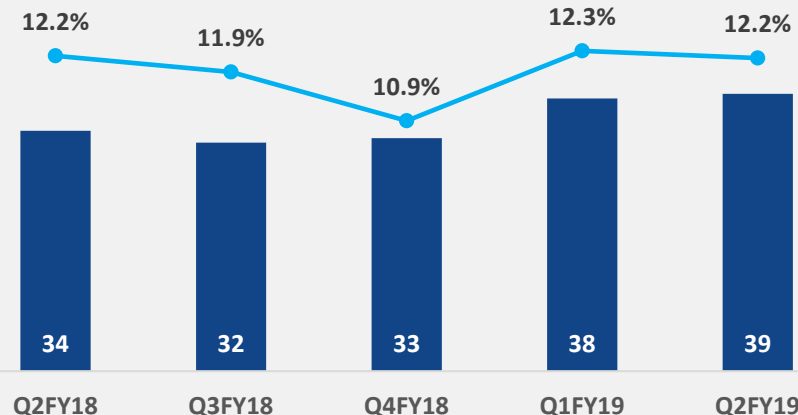

■ EBITDA ● EBITDA Margin (%)

PBT & PBT Margin

In INR Cr

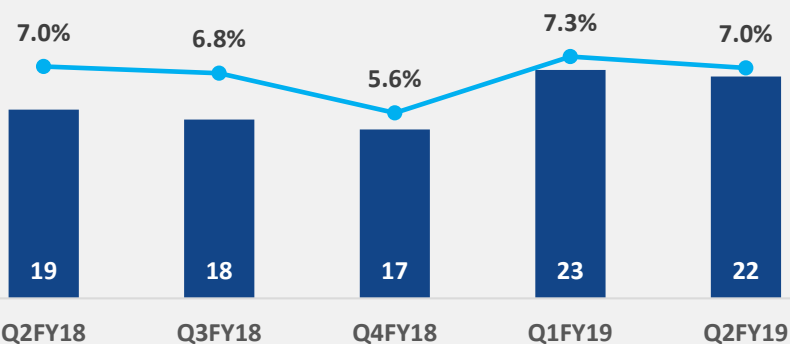

■ PBT ● PBT Margin (%)

PAT & PAT Margin

In INR Cr

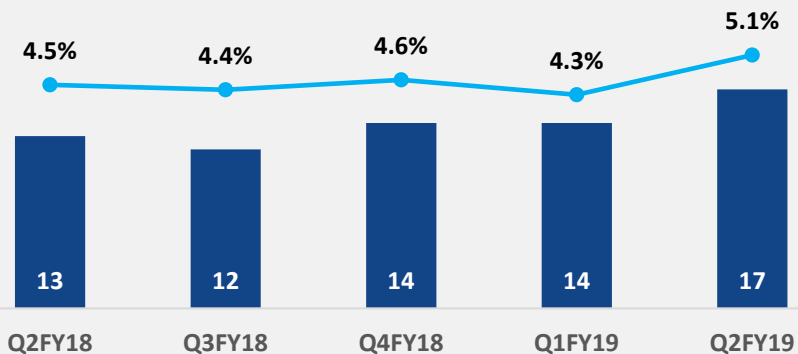

■ PAT ● PAT Margin (%)

In INR Cr			Particulars	In INR Cr		
YoY(%)	Q2FY18	Q2FY19		Q2FY19	Q2FY18	YoY(%)
16%	277.19	321.01	Total Revenue (inclusive of other income)	364.25	304.48	20%
-24%	6.51	4.94	Other Income	3.03	4.49	-33%
16%	257.77	298.67	Total Expenses	339.87	285.48	19%
15%	33.88	39.09	EBITDA	45.58	37.19	23%
11%	10.01	11.07	Depreciation	14.54	13.29	9%
28%	4.45	5.68	Finance Cost	6.66	4.9	36%
			Profit from JV	0.82	-0.25	
-93%	1.75	0.13	Exceptional items	0.27	1.77	-85%
26%	17.67	22.21	PBT	24.93	16.98	47%
-28%	5.08	5.68	Tax	6.85	4.97	38%
47%	12.59	16.53	PAT	18.08	12.01	51%
47%	12.59	16.53	Net PAT (After non-controlling interest)	17.92	11.94	50%
	0.93	1.23	EPS	1.32	1.13	

In INR Cr			Particulars	In INR Cr		
Standalone				Consolidated		
YoY(%)	H1FY18	H1FY19		H1FY19	H1FY18	YoY(%)
16%	547.46	632.9	Total Revenue (inclusive of other income)	717.20	603.11	19%
-27%	13.92	10.25	Other Income	6.84	9.30	-26%
15%	512.4	587.77	Total Expenses	669.13	567.20	18%
37%	62.95	77.52	EBITDA	88.93	70.88	33%
9%	19.98	21.78	Depreciation	28.62	26.40	8%
34%	7.91	10.61	Finance Cost	12.24	8.57	43%
			Profit from JV	1.58	1.62	
121%	2.18	4.82	Exceptional items	5.10	2.60	96%
23%	32.88	40.31	PBT	44.55	34.93	28%
14%	8.96	10.21	Tax	11.26	8.93	26%
26%	23.92	30.10	PAT	33.29	26.00	28%
26%	23.92	30.10	Net PAT (After non-controlling interest)	33.16	25.99	28%
	1.77	2.25	EPS	2.45	1.92	

Shareholding Pattern

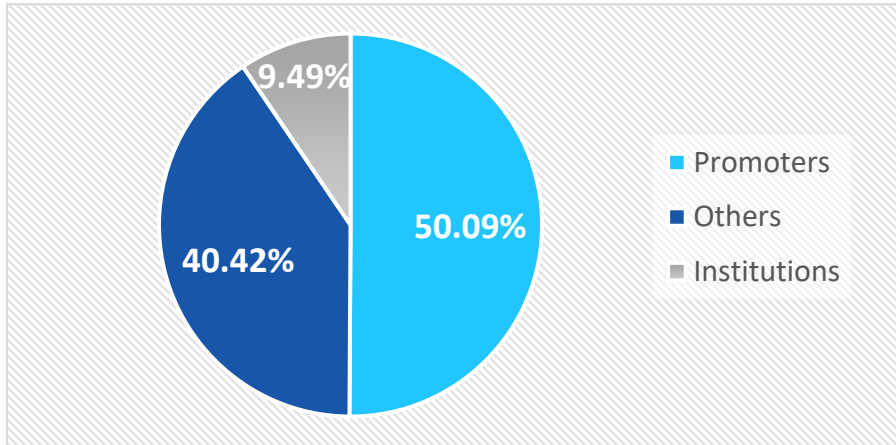

Stock Data

₹	Market Cap	933 Cr.
📈	Stock Price	₹ 68.95
↑↓	52 Week (High / Low)	₹ 108.40/61.45
📊	NSE / BSE - Symbol	RICOAUTO / 520008
📊	No. of Shares Outstanding	13.53 Cr.
📊	Free Float	48.94%

Stock Performance



Top Institutional Holding

Name	# Share	% O/S
RELIANCE NIPPON	4953230	3.66
L&T MUTUAL FUND TRUSTEE LIMITED	3198073	2.36
PRINCIPAL TRUSTEE COMPANY PVT LTD	1766790	1.31
ASHMORE INDIA OPPORTUNITIES FUND	1421081	1.05

lies A world class integrated supplier of Automotive Components
es A world class integrated supplier of Automotive Components
orld class integrated supplier of Automotive Components & Assemblies
ass integrated supplier of Automotive Components & Assemblies
ted supplier of Automotive Components & Assemblies A
plier of Automotive Components & Assemblies A world class
r of Automotive Components & Assemblies A world class
tive Components & Assemblies A world class integrated
ents & Assemblies A world class integrated supplier of Automoti
ts & Assemblies A world class integrated supplier of Automoti

RICO AUTO INDUSTRIES LIMITED

38 KM Stone, Delhi - Jaipur Highway,
Gurgaon - 122001, Haryana (INDIA)

Jagdish Dwivedi

Phone: +91 124 2824000 (D)

E-mail: rico@ricoauto.in

Website: www.ricoauto.com

Investor Relations

Sanidhya Jain

S-Ancial Technologies Pvt. Ltd.

215, Shivshakti Industrial Estate, J.R Boricha
Marg, Lower Parel (E) Mumbai-400011

Phone: +91 99 30 446788

E-mail: sanidhya@s-ancial.com

Website: www.s-ancial.com