

**RICO AUTO INDUSTRIES LIMITED**

CORP. OFF.: 38 K.M. STONE, DELHI - JAIPUR HIGHWAY, GURGAON 122001, HARYANA, INDIA
TEL.: +91 124 2824000, +91 124 4032200 FAX : +91 124 2824200
email : rico@ricoauto.in website : www.ricoauto.com CIN :L34300HR1983PLC023187

RAIL:SEC:2015

October 07, 2015

BSE Limited
Phiroze Jeejeebhoy Towers
Dalal Street
Mumbai - 400 001

Kind Attn: **Ms. Kruthika Shetty**

Ref : **Scrip Code - 520008**

Sub : **Corporate Presentation at Investor's Meet**

Madam,

We are enclosing herewith a copy of Corporate Presentation to be made at the meeting with Investors at Mumbai today i.e. 7th October, 2015. The same is also available at the Company's website www.ricoauto.com.

This is for your information and record.

Thanking you,

Yours faithfully,
for **Rico Auto Industries Limited**

B.M. Jhamb
Company Secretary
FCS : 2446

Encl : As above

RICO

A
WORLD CLASS
INTEGRATED SUPPLIER OF
**AUTOMOTIVE
COMPONENTS
&
ASSEMBLIES**



TEAMWORK
THE POWER OF WORKING TOGETHER

COMMITMENT
THE POWER OF RESPONSIBILITY, ACCOUNTABILITY AND OWNERSHIP

EXCITE

ENTREPRENEURSHIP
THE POWER OF PURSUING NEW CHALLENGES WITH SPEED, FLEXIBILITY AND OWNERSHIP

INTEGRITY
THE POWER OF HONESTY AND TRANSPARENCY

EXCELLENCE
THE POWER OF BEING THE BEST

- **Company Profile, Facilities & Locations**
- **Manufacturing & Engineering Capabilities**
- **Product Range**
- **Joint Ventures**
- **Financial Highlights**
- **India Automotive Industry Outlook**



Leading Integrated Supplier of Automotive Components & Assemblies

**Ferrous &
Aluminium**

**Casting &
Machining**

**Dies &
Moulds**

**Design &
Development**



**OEM
Supplier**

**ISO-TS
16949**

**ISO
14001**

**OHSAS
18001**

**FORD
Q1**

**CAT-SQEP
Bronze**

RICO Group Combined Turnover \$ 245 Million FY16

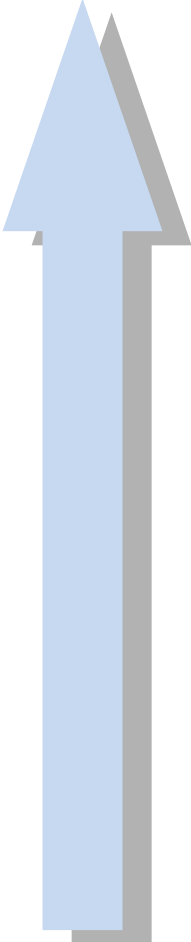

2010-14	Added new facilities/Plants – At Bawal, Bhiwadi, Sanand, Chennai & Haridwar Added Customers – GKN, Toyota, Bentley, VW, Kohler	
2007-09	JV with MAGNA Powertrain (Oil Pump, Water Pump) JV with Continental GmbH (Hydraulic Braking System) JV with Jinfei China (Aluminum Alloy Wheels – 2 Wheelers) Added Customers – JATCO, Mann & Hummel, Magna, Renault, BMW	FORD Q1 CAT SQEP-Bronze
2004-06	R&D Center Started Added Customers – NISSAN, TATA (Small Car Project), Perkins	
2003-04	Enhanced Ferrous and Aluminium Capacity Added Customers – GM, Caterpillar, Honeywell, Detroit Diesel, Volvo	
2000-02	Full Service Engineering Design Development Added Customers – FORD, LandRover, Jaguar	TS 16949 ISO 14001 OHSAS 18001
1999-00	Aluminium Die Casting & Machining (<i>Gurgaon</i>)	QS 9000
1994-96	JV (50:50) FCC RICO (Clutch Assembly) Started Exports – GM, Eaton, Cummins	
1990-92	International Market OEM Supplier – MEC Japan Ferrous Casting & Machining (<i>Gurgaon</i>) Focus – Maruti Suzuki	ISO 9000
1985-86	Technical Collaboration FCC Japan Commercial Production Started (1986) Aluminium Die Casting & Machining (<i>Dharuhera</i>) Focus – Hero Honda & Maruti Suzuki	



BAWAL



GURGAON



BHIWADI



HARIDWAR

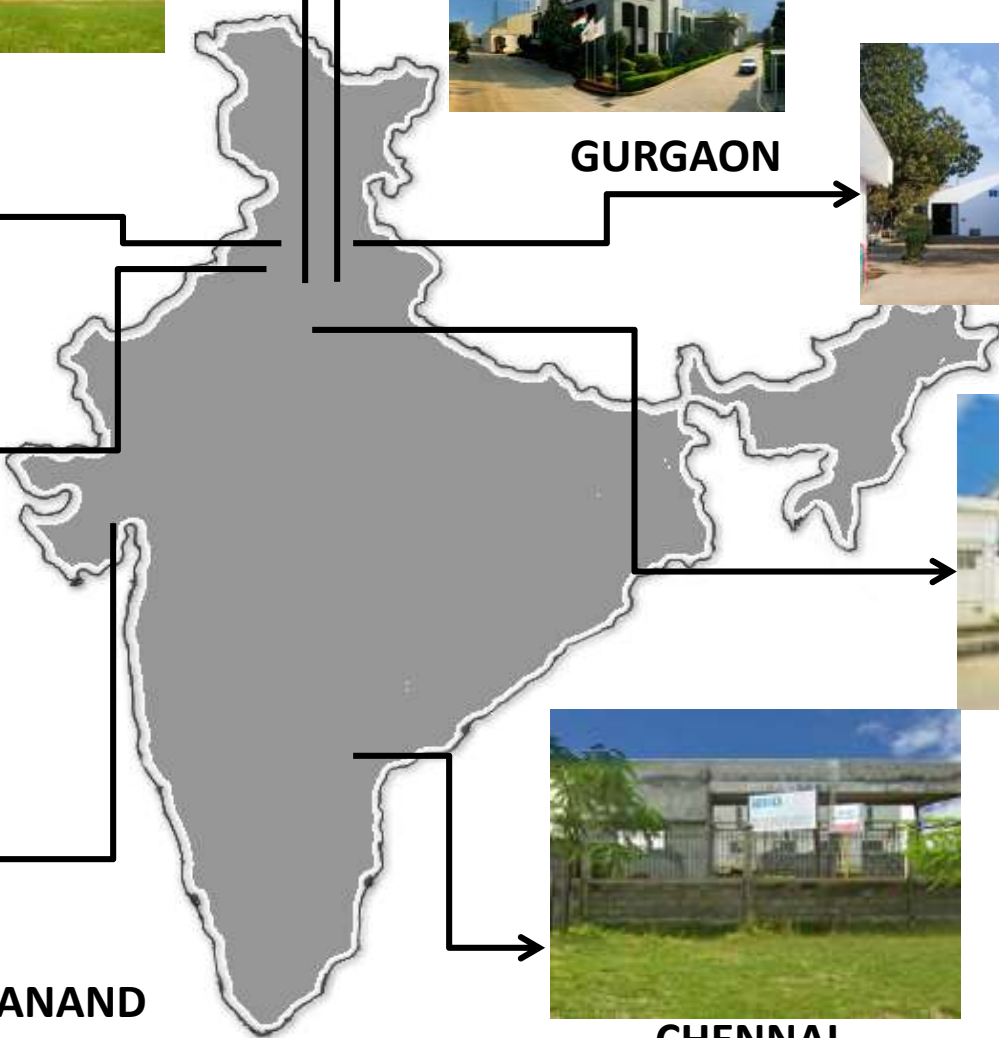

DHARUHERA



MANESAR



SANAND



CHENNAI



SOP – Sept 2015

HPDC

Customer – Renault - Nissan

Projections

FY 16 – 45 K

FY 17 – 150 K

FY 18 – 250 K

Est. Sales

170 Mn INR

540 Mn INR

900 Mn INR

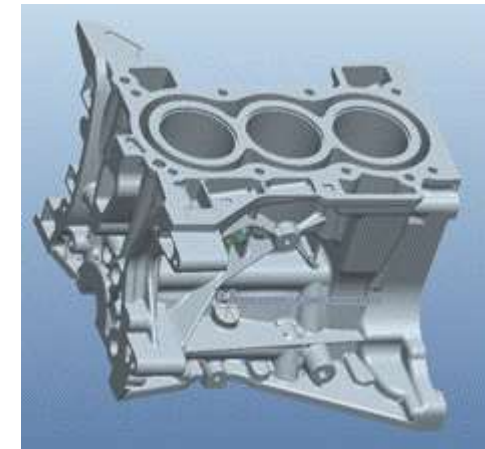
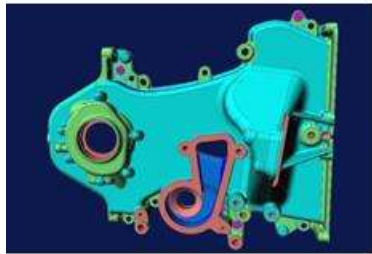

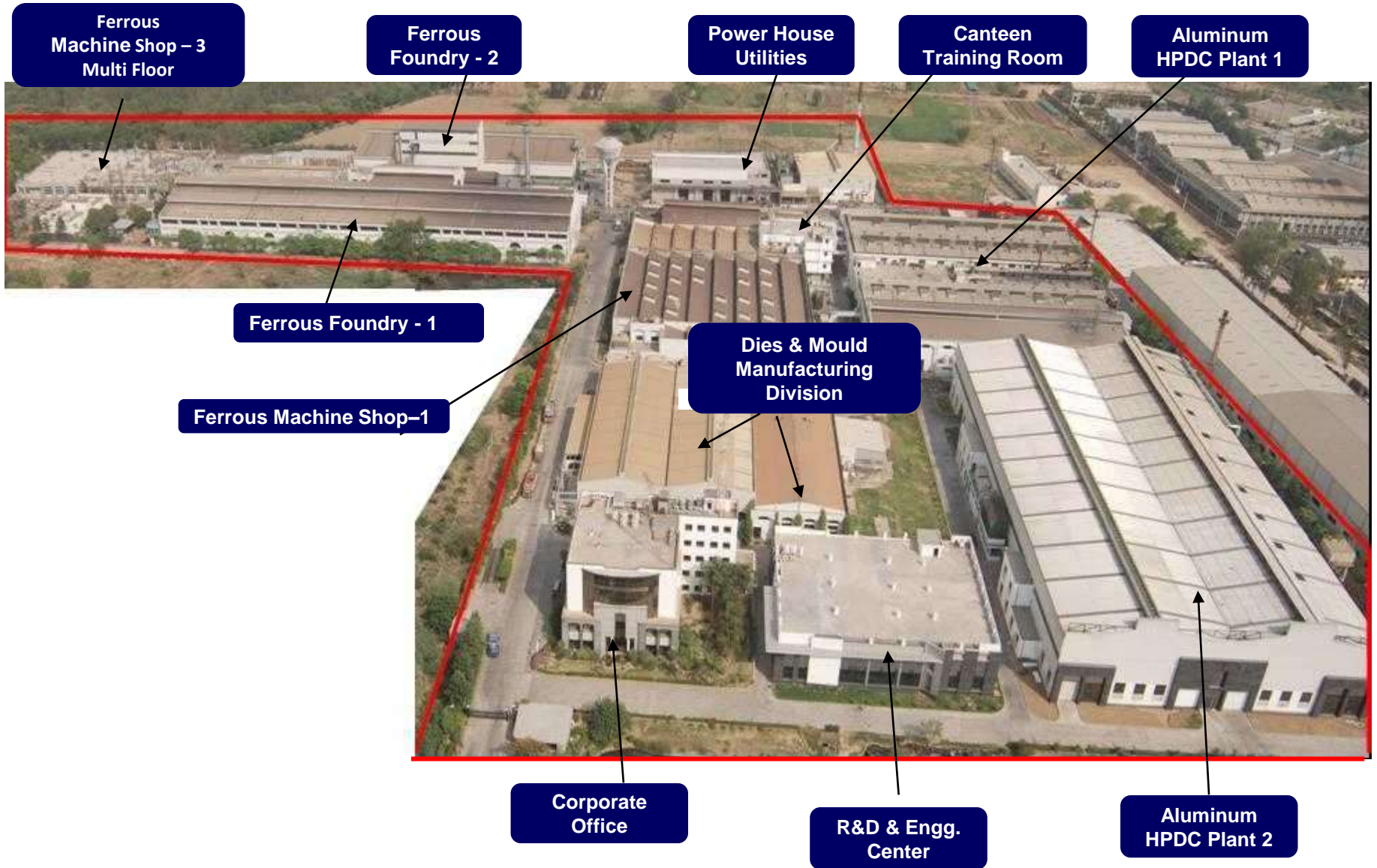

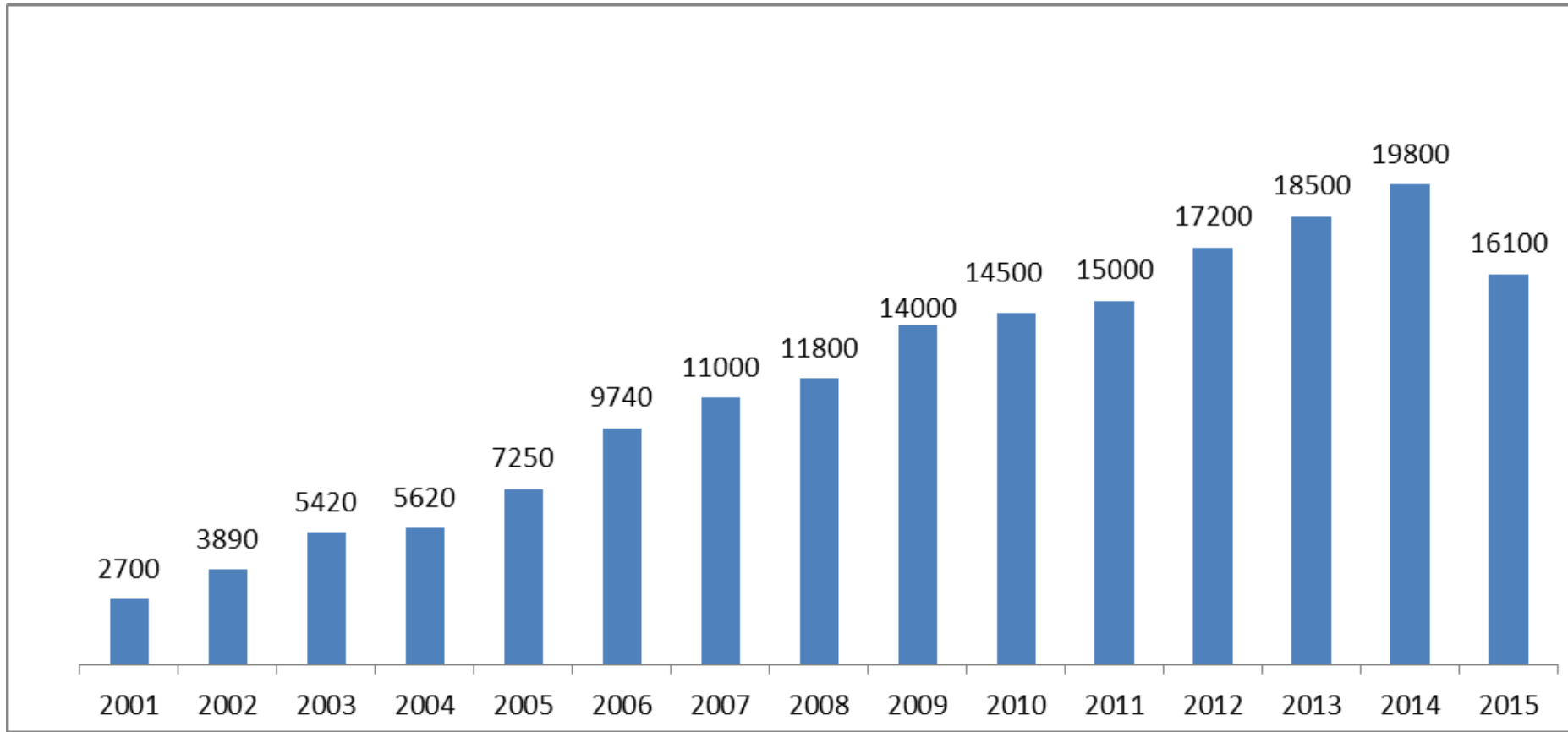

Two Wheelers



Four Wheelers



System Suppliers



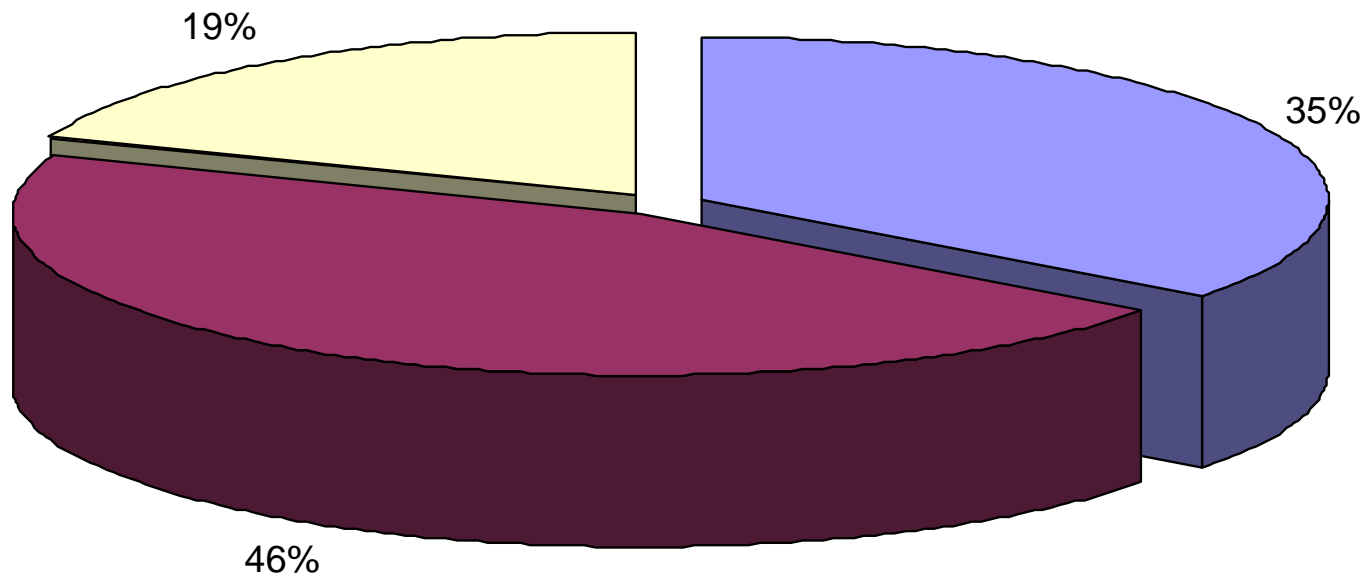

■ Engine ■ Transmission ■ Chassis Suspension & Braking System

Engine



- Oil Pump Assembly
- Fuel System Parts
- Lube Oil Filter head
- Exhaust Manifolds
- Turbine Housings
- Center Housings
- Crank Cases & Covers
- Cylinder Head Cover
- Oil Pan
- Intake Manifold Cover
- Engine Front Cover
- Valve Cover
- Balance Shaft Assembly
- Gear Housing
- Main Bearing Caps
- Water & Air Connections
- Timing Cases
- Cylinder Block (Aluminum)
- EGR Housing

Transmission



- Clutch Assembly
- Differential Case
- Gear Shift Forks
- Intermediate Plate
- Pressure Plate
- Rear Case
- Transmission Case
- Front Transmission Housing

Chassis & Braking System



- Wheel Hub Assembly
- Brake Panel Assembly
- Brake Disc
- Brake Drums
- Caliper & Anchor
- TMC Tandem Master Cylinder



Over 100 HPDC Machines (135 – 2500 Tns Locking Force). Largest HPDC Capacity in India including GDC & LPDC. Total Capacity 55000 Ton, Utilization ~ 65%



**4 Molding Lines - 2 DISA & 2 Horizontal (SINTO & DISA)
Material: Gray (FC), Ductile (FCD), SiMo, SiMo Chrome**

Casting Capacity 50000 Ton, Utilization ~ 65%



**Over 1,500 Machines (CNCs & SPMs) +
One of the Largest Machining Facility in India
Over 50% of Our Product Range is with Assemblies**

Capacities aligned to customer volumes

**Competitive Advantage: Manufacturing Experience Combined with Engineering CAD
CAM CAE Center**



Capabilities (Over 60 Seats)

CAD & CAM

Unigraphics, Pro E, Catia, C3P, Ideas, Vericut

CAE Computer Aided Engineering

Magmasoft, FEA, CFD, Ansys, FCX, GT Suite, MSC Fatigue

Advantages

Concurrent engineering with customers.

Shorter development time.

Inhouse designing, Modifications & product design optimization.

In-House Dies & Pattern Design & Manufacturing

Manufacture over 250 Dies & Patterns and 800 Die Inserts Annually



Recent Projects completed

Design & development of Dies for Engine Blocks, Bed Plates, Cylinder head, TM Case
Designing & Manufacturing of Dies for 2500 ton die casting machines.
Designing & Manufacturing of LPDC & GDC dies.

Clutch Assembly, Crank Cases & Covers

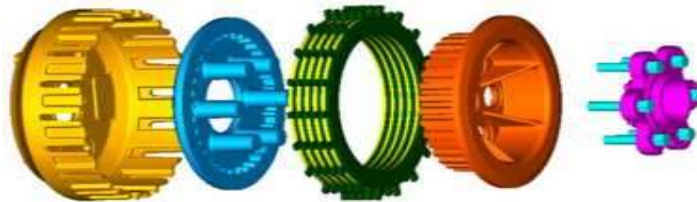
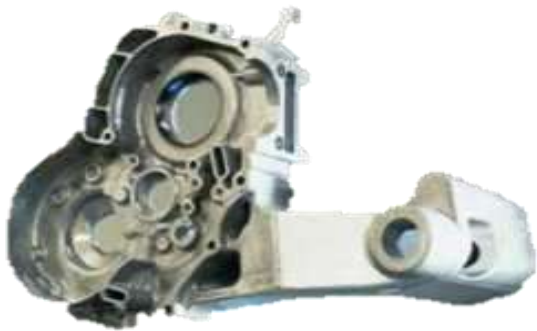

Cylinder Blocks, Oil Pans, Cylinder Head & Chain Covers, Bedplate, Oil & Water Pump Assemblies

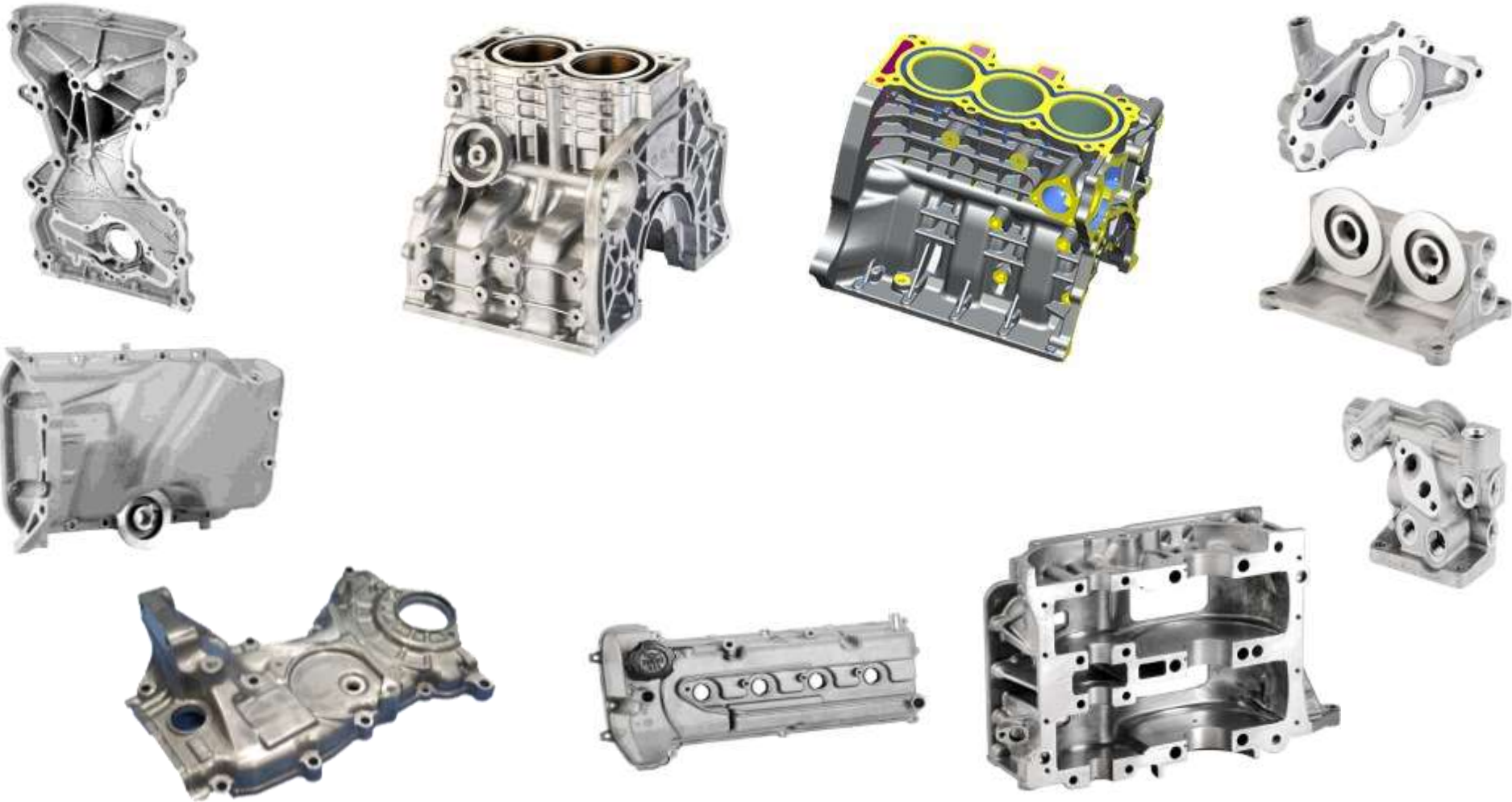

Transmission Housings, Cover Valves, Side Covers, Timing Cases



Differential Cases, Turbocharger Parts, Bearing Caps, Exhaust Manifolds, Retainer Bearings, Brake Drums, Rotors & Balance Shafts



Clutch Parts, Rear Cases & Anchor – Caliper Housings





**Oil Pump
Water Pump
(Automotive Engines)
(India & Europe)**

50% : 50%



Year	FY 14	FY 15	FY 16
Oil & Water Pump Assemblies (Nos)	678000	1041000	1215000
Turnover Mn INR	464	623	710



**Aluminum Alloy Wheels
Two Wheelers**

92.5% : 7.5%



Year	FY 14	FY 15	FY 16
Alloy Wheels	610000	900000	1020000
Turnover Mn INR	562	850	925



Rico Auto Financial Highlights (Consolidated)

INR Cr

	FY 15	FY 16
PARTICULARS	AUDITED ACTUALS	GUIDANCE ESTIMATE
* Net Sales	1,299.5	985.3
Other Income	79.3	26.4
Total Income	1,378.7	1,011.7
* PBIDT	129.4	103.3
PBIDT%AGE	9.4%	10.2%
Interest	52.8	19.8
Depreciation	84.6	49.2
PBT (Before Exceptional Items)	-7.9	34.4
# Exceptional One Time Gain	194.5	-
PBT (After Exceptional Items)	186.6	34.4

* Includes Sale/Profit from JV FCC RICO till Dec 14

Gain on Disinvestment from sale of shares in JV FCC RICO.

PV

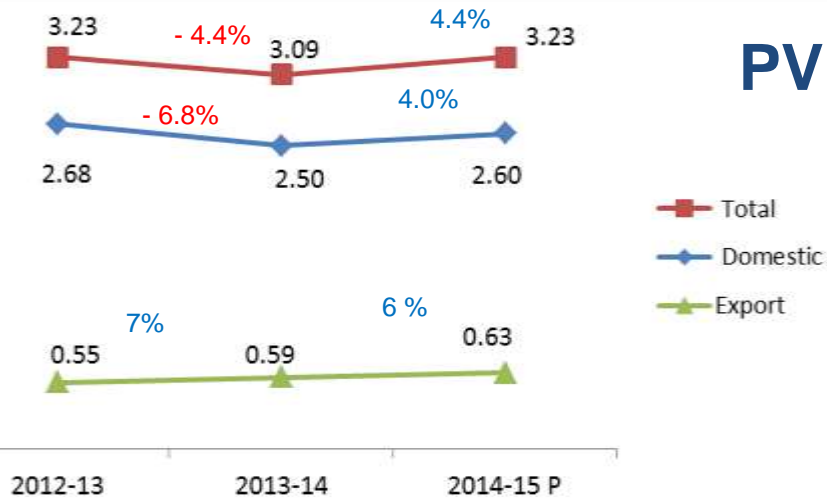

CV

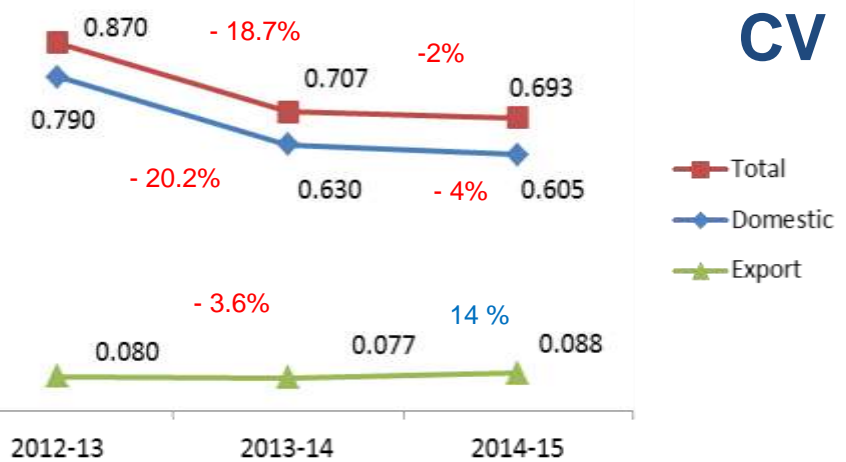

2W

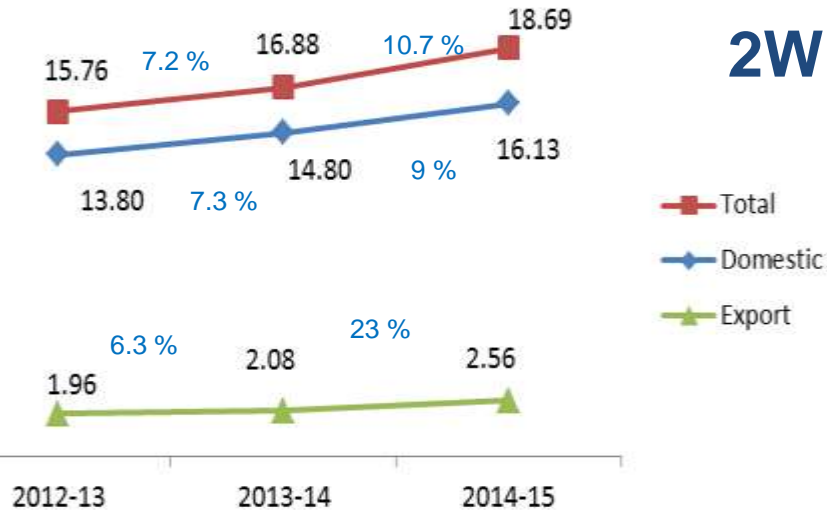

Overall

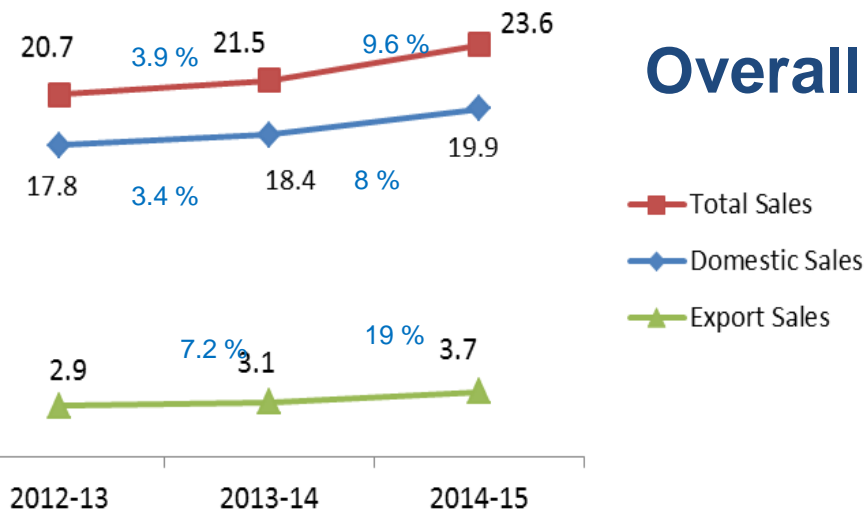

SIAM projection for 2015-16 PV 5-6%, 2W 8-10%, CV – 10-12%

Our Vision

“To be preferred supplier to OEMs across the globe”

Overall Strategies

Strategic Alliances & Joint Ventures

Expand Manufacturing Presence

Move from Components to Systems

Continuous Focus on Quality & Cost

World Class Human Resources & Plants